

Extra No. 348



सत्यमेव जयते

The Gujarat Government Gazette

EXTRAORDINARY

PUBLISHED BY AUTHORITY

Vol. LXIV] WEDNESDAY, DECEMBER 13, 2023 / AGRAHAYANA 22, 1945

Separate paging is given to this Part in order that it may be filed as a Separate Compilation.

PART IV-B

Rules and Orders (Other than those published in Parts I, I-A, and I-L) made
by the Government of Gujarat under the Gujarat Acts

URBAN DEVELOPMENT AND URBAN HOUSING DEPARTMENT

NOTIFICATION

Sachivalaya, Gandhinagar, 11th December, 2023

NO.GH/V/233 of 2023/UDUHD/TGP/e-file/18/2022/7201/L1-Branch: WHEREAS the circumstances exist which renders it necessary to repeal the Gujarat Fire Prevention and Life Safety Measures Regulations, 2016;

NOW THEREFORE in exercise of the powers conferred by sub-section (2) of section 18 of the Gujarat Fire Prevention and Life Safety Measures Act, 2013, the Government of Gujarat hereby makes the following regulations, namely: -

CHAPTER I- PRELIMINARY**1. Short title, Extent and Commencement**

- 1.1. These regulations may be called the Gujarat Fire Prevention and Life Safety Measures Regulations, 2023.
- 1.2. It extends to the whole of the State of Gujarat.
- 1.3. They shall come into force on the date of its publication in the *Official Gazette*.

2. Applicability

- 2.1. These regulations shall be applicable for the buildings listed in THIRD SCHEDULE of the Gujarat Fire Prevention and Life Safety Measures (Amendment) Rules, 2021.

3. Repeal and saving

- 3.1. The Fire Prevention and Life Safety Regulations, 2016 and subsequent notifications thereunder, is hereby repealed.
- 3.2. Notwithstanding such repeal, anything done or any action taken under the repealed regulations shall be deemed to be valid and continue to be so valid.
- 3.3. All existing orders and directions that are in conflict or inconsistent with these regulations shall stand modified to the extent of the provisions of these regulations.
- 3.4. In case where construction has commenced as per valid development permission granted prior to coming into force of these regulations, the fire safety certificate may be issued as per the repealed regulations, if fire safety plan is approved before coming into force of this regulations.

4. Definitions

- 4.1. In these Regulations, unless the context otherwise requires: -

- (a) "Act" means the Gujarat Fire Prevention & Life Safety Measures Act, 2013 (Guj. Act No. 11 of 2013) along with its amendment;
- (b) "applicant" means an owner or occupier intending to make an application for development under section 26 of the Gujarat Town Planning and Urban Development Act, 1976;
- (c) "appropriate authority" means an appropriate authority as defined under clause (iii) of section 2 of the Gujarat Town Planning and Urban Development Act, 1976;
- (d) "competent authority" means any person or persons or Authority or Authorities authorized by the Urban Development Authority or the Area Development authority as the case may be, to perform such functions as may be specified;
- (e) "enclosed Staircase" means a staircase separated by fire resistant walls and doors from the rest of the building;
- (f) "erector of pandal" means a person or an association of persons, whether corporate or otherwise, who erects or makes a pandal or any structure for occupation of people on a regular or temporary basis;
- (g) "escalator" means a power driven inclined continuous stairway used for raising or lowering passengers;
- (h) "external wall" means an outer wall of a building not being a partition wall and also means a wall abutting on an interior open space of any building;
- (i) "exit" means a passage, channel or means of egress from any building, storey or floor area to a street or other open space of safety;
- (j) "fire authority" means the Director or the Regional Fire Officer or the Chief Fire Officer or his nominee or any other person authorized by the competent authority;
- (k) "fire drenchers" means system of water heads used for the fire protection on the exterior of a building tend to be positioned on roofs and over windows and external openings and where nozzles are activated simultaneously;

- (l) "fire and/or emergency alarm system" means an arrangement of call points or detectors, sounders and other equipment for the transmission and indication of alarm signals working automatically or manually in the event of fire;
- (m) "fire pump" means a machine, driven by external power for transmitting energy to fluids by coupling the pump to a suitable engine or motor, which may have varying outputs/capacity but shall be capable of delivering a pressure of 3.5 kg/cm² at the topmost level of multistory or high rise building;
- (n) "fire safety certificate" means the fire safety certificate issued under sub-rule (1) of Rule 23;
- (o) "fire safety certificate renewal" means the fire safety certificate renewal issued under Rule 25;
- (p) "fire safety executive" means a person appointed under regulation No.27 for specific buildings;
- (q) "fire safety officer" means a person or an association of persons appointed under section 12 of the Act as the Fire Safety Officer by the owners and occupiers of certain premises and buildings as prescribed in this behalf for fire safety certificate renewal and such other related activities required to be carried out under this Act;
- (r) "fire safety plan" means a plan showing the minimum requirement, capacity and location of fire prevention, life safety and fire protection measures;
- (s) "fire service inlet" means a connection provided at the base of a building for pumping up water through-in-built fire-fighting arrangements by fire service pumps in accordance with the recommendation of the Regional Fire Officer or the Chief Fire Officer;
- (t) "fire staircase" means an enclosed staircase which can only be approached from the various floors through landings or lobbies separated from both the floor area and the staircase by fire resisting doors;
- (u) "fuel station" means a place of retails business engaged in supplying and dispensing of fuel products to consumers essential for the normal operation of automobiles;
- (v) "hazardous material" means materials as defined in National building code of India (Part 4) and also includes radioactive substances;
- (w) "lift /elevators" means a mechanically guided car, platform or transport for persons and materials between two or more levels in a vertical or substantially in a vertical direction;
- (x) "lift well" means unobstructed space within an enclosure provided for the vertical movement of the lift car(s) and any counter weight(s), including the lift pit and the space for top clearance, and maintenance;
- (y) "non-combustible" means not liable to burn or add heat to a fire when tested for non-combustibility in accordance with the "IS :3808 Method of test for non- combustibility of building materials";
- (z) "pandal" means a temporary structure with roof or walls made of straw, hay, ulu grass, golpatta, hogla, darma, mat, canvas, cloth or other like material which is not adopted for permanent or continuous occupancy;
- (aa) "permanent open air space" means air space permanently open;
- (bb) "Rules" means the Gujarat Fire Prevention & Life Safety Measures Rules, 2014 along with its amendment;
- (cc) "smoke-stop door" means a door for preventing or checking the spread of smoke from one area to another;
- (dd) "stair cover" means a structure with a covering roof over a staircase and its landing built to enclose only the stairs for the purpose of providing protection from the weather, and not to be used for human habitation;
- (ee) "temporary structure" means structures erected for temporary purpose or ceremonial occasions such as tents, hutments, shamiyana, pandals, etc.

- 4.2. The words and expressions not defined in this section shall have the meaning as defined in the Act, Rules, National building code of India (Part 4 Fire and Life Safety), IS 8757:1999 (Glossary of terms associated with fire safety) and IS7673:2004 (Fire Fighting Equipment - Glossary of Terms) as amended from time to time.
- 4.3. The meaning of words and expressions defined in these regulations shall prevail over the meaning of words and expressions if the same is defined in the CGDCR made under the provisions of the Gujarat Town Planning and Urban Development Act, 1976.
- 4.4. Wherever the words "the Regional Fire Officer or the Chief Fire Officer" or "the Chief Fire Officer or the Regional Fire Officer" appear in these regulations, it shall mean "the Regional fire Officer or the Chief Fire Officer or any other officer authorized by the Director".

CHAPTER II- ISSUANCE OF FIRE SAFETY CERTIFICATE AND ITS RENEWAL

5. Procedure for obtaining fire safety plan approval

- 5.1. Any applicant seeking the development permission under the Gujarat Town Planning and Urban Development Act, 1976 in any Fire Region, with regard to any building or premises mentioned in Third Schedule of the Rules, shall make an application as per **ANNEXURE 1** to the Regional Fire Officer or the Chief Fire Officer, as the case may be, for obtaining the Fire Safety Plan Approval with requisite fees as may be prescribed, the required documents and building plans showing the minimum requirement, capacity and location of fire prevention, life safety and fire protection measures. The application shall be countersigned by the owner / builder/ developer and the Licensed Agency/ architect on record / engineer on record / structural engineer on record.
- 5.2. On receipt of the application made under regulation No. 5.1, the Regional Fire Officer or the Chief Fire Officer as the case may be shall, within a period of 21 days, scrutinize the same and on being satisfied that for the development proposed, the minimum requirement and location of fire prevention, life safety and fire protection measures as required under these regulations are shown in the fire safety plans, shall issue "Fire Safety Plan Approval" (FSPA) letter as per **ANNEXURE 2**. The fire safety plan may be rejected as per **ANNEXURE 3** mentioning the reasons thereof. On the basis of this "Fire Safety Plan Approval" letter, the competent authority may grant the development permission under the provisions of the Gujarat Town Planning and Urban Development Act, 1976.
- 5.3. Prior to occupancy or use of any building specified in regulation No. 5.1, the owner / builder/ developer and the Licensed Agency / architect on record / engineer on record / structural engineer on record shall make an application for obtaining fire safety certificate to the Regional Fire Officer or the Chief Fire Officer, as the case may be, in "**FORM-B14**" of the Rules, along with the requisite fees as may be prescribed, for certifying that the completed construction complies with the minimum requirement and location of fire prevention, life safety and fire protection measures as required under these regulations and as shown in the fire safety plans on basis of which the "Fire Safety Plan Approval" certificate was issued.

Following self-certifications shall be submitted along with the application for Fire Safety Certificate Approval;

- a) Self-certification by the Owner/ Occupier/ Builder/ Developer for maintaining fire prevention, life safety and fire protection measures as per approved fire safety certificate and doing no alteration of any part of the building without approval of the competent authority (**ANNEXURE 13**)
- b) Self-certification by the Owner/ Occupier/ Builder/ Developer having done Annual Maintenance Contract (AMC) for fire protection equipment and system installed in the building/ premise (**ANNEXURE 14**)
- c) Self-certification by owner/ occupier/ builder/developer regarding safe electrical installations inside building or premise (**ANNEXURE 15**)

When applying for fire safety certificate, in case there is a deviation from approved fire safety plan with regard to requirement and locations of fire prevention, life safety and fire protection measures, the fire safety plan has to be approved again as per the fire prevention, life safety and fire protection measures actually provided in the building / premises, after paying prescribed fee for fire safety plan approval (**ANNEXURE 8**), and then only application can be processed for the fire safety certificate.

- 5.4. On receipt of the application made under clause 5.3, the Regional Fire Officer or the Chief Fire Officer as the case may be, within a period of 21 days, scrutinize the same and after making such inquiry as it may deem fit, including the site visit, inspection, testing and on being satisfied that the construction completed fulfills the minimum requirements for fire prevention, life safety and fire protection measures, as required under these regulations, shall issue the fire safety certificate(FSC) in the prescribed "**FORM-B13**" of the Rules.
- 5.5. The Regional Fire Officer or the Chief Fire Officer as the case may be, may reject the application for issuance of fire safety certificate and inform the owner / builder/ developer and the Licensed Agency / architect on record / engineer on record / structural engineer on record as per **ANNEXURE 4** by mentioning the reasons thereof.
- 5.6. In case of rejection of application for grant of fire safety certificate under regulation No. 5.5, a fresh application shall be made by the owner or occupier under regulation No. 5.3 duly complying with the requirements as communicated under regulation No. 5.5.
- 5.7. This fire safety certificate shall be valid for a period of three years from the date of issue unless cancelled by the Regional Fire Officer or the Chief Fire Officer after recording the reasons thereof.
- 5.8. The buildings or premises that have already been issued 'No Objection Certificate' for the occupancy of the building or premises shall deemed to have been issued Fire Safety Certificate under Rule 23 subject to verification of compliance of fire prevention, life safety and fire protection measures on which the 'No Objection Certificate' was issued on the last occasion.
- 5.9. The procedure of obtaining fire safety plan approval, issuance of fire safety certificate, uploading the required documents and plans, payment of requisite fees as may be prescribed, etc. need to be done on the Web portal <https://gujfiresafetycop.in>.

6. Enrolment of fire safety officer (FSO)

- 6.1. The Director shall issue the enrolment certificate to the fire safety officer in "**Form-B12**" of the Rules, after their successful completion of the training prescribed in the Rules and shall upload their details on the Web portal <https://gujfiresafetycop.in>.
- 6.2. The fire safety officer so enrolled can work anywhere in the State of Gujarat.
- 6.3. Any company wishing to enroll as fire safety officer must have a minimum of three fire safety officers which include at least one fire safety officer of Specialist grade.
- 6.4. The duties of fire safety officer shall be as prescribed in the FOURTH SCHEDULE of the Rules.
- 6.5. Fire safety certificate renewal shall be processed by the fire safety officers of different Grade for the type of buildings or premises, as specified in the FOURTH SCHEDULE of the Rules.
- 6.6. The owner or occupier shall appoint a fire safety officer who has no conflict of interest i.e., the appointed fire safety officer shall not have been involved in installation of fire protection and life safety measures in the same building/ premise for which he/ she has been appointed as fire safety officer. He/she shall not, in any case, issue fire safety certificate renewal for the building/ premises where he/she is employed/ engaged.
- 6.7. Licensed Agency cannot work as fire safety officer for the building/ premises for which owner or occupier has engaged it as a Licensed Agency.

7. Procedure for renewal of fire safety certificate

- 7.1. To get the fire safety certificate renewed (FSCR), every owner or occupier of the building or premises mentioned in THIRD SCHEDULE of the Rules and has been issued the fire safety certificate, shall appoint a fire safety officer from the list of fire safety officer enrolled by the Director, the details of which, shall be available on the Web portal <https://gujfiresafetycop.in>.
- 7.2. The owner or occupier shall appoint fire safety officer within two months prior to expiry of the validity of fire safety certificate issued under regulation No. 5.4 and upload the details on the Web portal <https://gujfiresafetycop.in>.

- 7.3. However, in case where validity of the fire safety certificate of the existing building or premises mentioned in THIRD SCHEDULE of the Rules has expired on the date of coming into force of these regulations, the owner or occupier shall appoint fire safety officer as per regulation No. 6.0 and get the fire safety certificate renewed (FSCRe) for such existing building or premises through such appointed fire safety officer but not later than 90 days from coming into force of these regulations. In case fire safety certificate is not renewed within the said time limit, the fire safety certificate shall be treated as null and void; renewal shall not be permitted and In case, Fire Safety certificates is not obtained within the timelines defined above, the owner or occupier shall apply for the fire safety certificate again with penalty charges in the online system.
- 7.4. In case of a vacancy of the fire safety officer appointed under regulation No. 6.2 or 6.3, either on resignation or otherwise, the owner or occupier individually or jointly, as the case may be, shall immediately appoint the fire safety officer. In case of failure to do so, the Regional Fire Officer or the Chief Fire Officer may issue the notice for appointment of fire safety officer as per ANNEXURE 5.
- 7.5. The fire safety officer so appointed, shall inspect the building or premises for which he or she is appointed, to verify the compliance of relevant Rules and these regulations and on satisfaction that fire prevention, life safety and fire protection measures are in good repair and efficient operational condition and self-certifications as mentioned in Regulations No. 5.3 have been submitted, may issue a Fire Safety Certificate Renewal (FSCR) in "Form-B13.3" of the Rules, valid for a period of two years from the date of issue and for the same period thereafter.
- 7.6. After inspection of the building or premises, the appointed fire safety officer on being satisfied that owner or occupier has failed to ensure the compliance of relevant Rules and regulations and the provisions as laid down in the fire safety certificate or has change the use of building or premises or its part, shall reject the fire safety certificate renewal as per ANNEXURE 6 and inform the owner / occupier and the concerned Regional Fire Officer or the Chief Fire Officer as the case may be.
- 7.7. In case of fire safety officer rejecting the fire safety certificate renewal under regulation No. 6.6, the owner or occupiers individually or jointly shall comply immediately with the requirements as communicated under regulation No.6.6.
- 7.8. In case of failure to appoint a fire safety officer as specified in regulation No. 6.2 or 6.3, the Regional Fire Officer or the Chief Fire Officer shall take appropriate action and/or communicate to the concerned competent authority to take appropriate action for the discontinuance of the use or closure of the building or premises or part thereof, as the case may be.

8. Annual and Bi-annual Declarations and Mock Drills

- 8.1. During the period of validity of the Fire Safety Certificate i.e. from the date of issuance till the first renewal of the same, the Licensed Agency shall give an annual declaration in "Form-B2" of the Rules, stating that the fire prevention, life safety and fire protection measures provided in the building or premises are operational, in good repair and efficient condition as specified in sub-section (2) of section 29 of the Act. This declaration shall be submitted to the Regional Fire officer or the Chief Fire officer not later than 15 days every year on completion of first and second year from the date of issue of fire safety certificate and it shall be uploaded on the Web portal <https://gujfiresafetycop.in>.
- 8.2. In case of Licensed Agency is not appointed, annual declarations in "Form-B2" of the rules, shall be given by the owner or occupier individually or jointly or by the developer as provided for in regulation No. 8.1.
- 8.3. The fire safety officer appointed as per regulation No. 6.2 or 6.3, after inspection of the building or premises shall declare every six months from the date of issue of fire safety certificate renewal (FSCR/FSCRe) in "Form-B15" of the Rules that fire prevention, life safety and fire protection measures provided in the building or premises are operational, in place and in best repairs.
- 8.4. The six-monthly declaration cum inspection report as per regulation No. 5.3 shall be uploaded on the Web portal <https://gujfiresafetycop.in> by the fire safety officer within stipulated time. Failure to do so may attract penalty as mentioned in regulation 11.
- 8.5. The fire safety officer shall also perform bi-annual emergency mock drills along with inspection of the fire safety measures and give declaration and maintain record of the same. Refer ANNEXURE 11 for checklist of mock fire and emergency drill and ANNEXURE 12 for the building/premise Inspection Checklist.

9. Check Lists

- 9.1.** The details of Form Code of checklist, which is a part of the application form, specifying mandatory requirement for fire protection measures in the building/ premises based on building occupancies and categories, for Fire Safety Plan Approval (FSPA), Fire Safety Certificate Approval (FSCA) and Fire Safety Certificate Renewal (FSCR) are as mentioned in the **TABLE-1** and for Fire Safety Certificate Renewal of the fire safety certificate issued prior to coming into force of these regulations (FSCRe) are as mentioned in **TABLE-2**.

Refer National building code of India- Part 4 for understanding the categorization of occupancy sub-type which is mentioned within brackets in Column 2 of the said TABLE 1

Irrespective of what is mentioned in FOURTH SCHEDULE of the amended Rules, 2021, for the purpose of FSCRe, the classification of buildings/ premises for appointment of FSOs for renewal of FSCRe, the grade of FSO shall be as mentioned in column 6 of TABLE 2 below.

- 9.2.** The Checklists for various building categories are as per **ANNEXURE 7.1 to 7.183** of these regulations. The checklists are available on the web portal <https://gujfiresafetycop.in>. For convenience of citizens and users, commonly used nomenclature may have been used in the Checklists on the web portal.

TABLE 1: Details of Form Code for referring the checklists related to FSPA, FSCA & FSCR

Occupancy Main Type	Occupancy Sub-Type (Refer NBC code Part 4)	Sr. No.	Building Categories	Form Code (FSPA)	Form Code (FSCA)	Form Code (FSCR)
1	2	3	4	5	6	7
Residential & Lodging	Dormitories, Flats, Hostels & Apartment Houses etc. (A-3) & (A-4)	1	15 m and above but not exceeding 35 m in height	C1R1-P	C1R1-C	C1R1-R
		2	Above 35 m but not exceeding 45 m in height	C1R2-P	C1R2-C	C1R2-R
		3	Above 45 m but not exceeding 60 m in height	C1R3-P	C1R3-C	C1R3-R
		4	Above 60 m but less than 100 m in height	C1R4-P	C1R4-C	C1R4-R
	Hotels & Guest Houses etc. (Below 5 star) (A-5)	5	Less than 15 m in height Floor area exceeding 500 m ² but not more than 1000 m ² on any of the floor	C1R5-P	C1R5-C	C1R5-R
		6	Less than 15 m in height Floor area exceeding 1000 m ² on any of the floor	C1R6-P	C1R6-C	C1R6-R
		7	15 m and above but not exceeding 30 m in height	C1R7-P	C1R7-C	C1R7-R
		8	Above 30 m but less than 100 m in height	C1R8-P	C1R8-C	C1R8-R
	Hotels 5 Star and Above (A-6)	9	5 Star and above hotels, resorts etc.	C1R9-P	C1R9-C	C1R9-R

Occupancy Main Type	Occupancy Sub-Type (Refer NBC code Part 4)	Sr. No.	Building Categories	Form Code (FSPA)	Form Code (FSCA)	Form Code (FSCR)
1	2	3	4	5	6	7
Educational Institute (Non-Residential part)	Schools (Non-Residential) (B-1)	10	More than 9 m but less than 15 m in height or Floor area more than 500 m ² on any one or more floors	C2ED1-P	C2ED1-C	C2ED1-R
	Other Educational and Training Institutions (Non-Residential) (B-2)	11	15 m and above but not exceeding 24 m in height	C2ED2-P	C2ED2-C	C2ED2-R
		12	Above 24 m but not exceeding 30 m in height	C2ED3-P	C2ED3-C	C2ED3-R
Institutional (Hospital, Correctional Facility, Care Centers etc.)	Hospitals, Sanatoria and Nursing Homes (C-1)	13	Less than 15 m in height Plot area upto 1000 m ² And Floor area more than 500 m ² on any one or more floors (upto ground plus one storey with beds)	C3I1-P	C3I1-C	C3I1-R
		14	Less than 15 m in height Plot area upto 1000 m ² (Ground plus two or more storey with beds)	C3I2-P	C3I2-C	C3I2-R
		15	Less than 15 min height with plot area more than 1000 m ²	C3I3-P	C3I3-C	C3I3-R
		16	15 m and above but less than 24 m in height	C3I4-P	C3I4-C	C3I4-R
		17	Above 24 m and not exceeding 45 m in height	C3I5-P	C3I5-C	C3I5-R
		Custodial (C-2), Penal & Mental (C-3)	18	Less than 10 m in height (upto 300 persons)	C3I6-P	C3I6-C
	19		Less than 10 m in height (more than 300 persons)	C3I7-P	C3I7-C	C3I7-R
	20		10 m and above but not exceeding 15 m in height	C3I8-P	C3I8-C	C3I8-R

Occupancy Main Type	Occupancy Sub-Type (Refer NBC code Part 4)	Sr. No.	Building Categories	Form Code (FSPA)	Form Code (FSCA)	Form Code (FSCR)
1	2	3	4	5	6	7
		21	15 m and above but not exceeding 24 m in height	C3I9-P	C3I9-C	C3I9-R
		22	24 m and above but not exceeding 30 m in height	C3I10-P	C3I10-C	C3I10-R
Assembly (Permanent Structures like - Cinema Halls, Party Plot, Stadium, Shopping Malls, Stations etc.)	Cinema, Multiplexes, Concert Halls, Studios (with audience facility), Auditoriums, Theatres, Party Plots (indoor), Marriage Halls, Community Centre, Banquet Halls, Court Rooms, Lecture Halls, Town Halls, Religious Structure, Museum, Heritage Monument, Airport Terminal Buildings, Enclosed Railway Stations, Enclosed Bus Depots, High Speed Rail Stations, Inter-modal Hubs, Stadium, Sports Complex, Amusement Park, Recreational Center etc. (D-1 to D-5)	23	Less than 10 m in height (upto 300 persons)	C4A1-P	C4A1-C	C4A1-R
		24	Less than 10 m in height (more than 300 persons) or Floor area more than 500 m ² on any one or more floors	C4A2-P	C4A2-C	C4A2-R
		25	Above 10 m but not exceeding 15 m in height	C4A3-P	C4A3-C	C4A3-R
		26	Above 15 m but not exceeding 24 m in height	C4A4-P	C4A4-C	C4A4-R
		27	Above 24 m but not exceeding 30 m in height	C4A5-P	C4A5-C	C4A5-R
		Shopping Malls (D-6)	28	Shopping Malls	C4A6-P	C4A6-C
	Metro & Mass Transport Systems (D-7)	29	Underground & Elevated Mass Rapid Transit system	C4A7-P	C4A7-C	C4A7-R
Business & Offices	Business (E-1 to E-5) - These buildings include Offices, banks, professional establishments (E-1), outpatient clinics, research establishments, libraries and test houses (E-2), Electronic data processing centres, computer installations, IT parks (E-3), Telephone exchanges (E-4), Broadcasting stations, T.V. stations and ATC towers (E-5)	30	Above 15 m but not exceeding 24 m in height or Floor area more than 500 m ² on any one or more floors	C5B1-P	C5B1-C	C5B1-R
		31	Above 24 m but not exceeding 30 m in height	C5B2-P	C5B2-C	C5B2-R
		32	Above 30 m but less than 100 m in height	C5B3-P	C5B3-C	C5B3-R
Mercantile & Shops	Mercantile Buildings including Super Store, Super Market, Department Store, Wholesale Market buildings etc. - these include Shops, stores,	33	Less than 15 m in height and Ground storey + one, having total floor area > 500 m ²	C6M1-P	C6M1-C	C6M1-R

Occupancy Main Type	Occupancy Sub-Type (Refer NBC code Part 4)	Sr. No.	Building Categories	Form Code (FSPA)	Form Code (FSCA)	Form Code (FSCR)
1	2	3	4	5	6	7
	markets having floor area < 500 m ² (F-1) and floor area > 500 m ² (F-2)	34	Above 15 m but not exceeding 24 m in height	C6M2-P	C6M2-C	C6M2-R
		35	Above 24 m but not exceeding 30 m in height	C6M3-P	C6M3-C	C6M3-R
	Underground Shopping Complex (F-3)	36	Underground Shopping Centre	C6M4-P	C6M4-C	C6M4-R
Storage, Warehouses, Transport Terminal & Parking	Storage, Warehouses & Parking (H)	37	Below 15 m in height covered area > 250 m ² Ground floor only or Floor area more than 500 m ² on any one or more floors	C8S1-P	C8S1-C	C8S1-R
		38	Below 15 m in height covered area > 250 m ² Ground plus one floor	C8S2-P	C8S2-C	C8S2-R
		39	Below 15 m in height covered area > 250 m ² Ground plus more than one floor	C8S3-P	C8S3-C	C8S3-R
		40	Multi-level Car Parking	C8S4-P	C8S4-C	C8S4-R
Hazardous or Flammable Material Storage & Handling	Hazardous or Flammable Material Storage & Handling (J)	41	Upto 15 m in height Single Storey building	C9H1-P	C9H1-C	C9H1-R
		42	Upto 15 m in height more than one floor building	C9H2-P	C9H2-C	C9H2-R
Mixed Use Occupancies	Commercial Complexes	43	Buildings above 9 m but not exceeding 15 m in height or Floor area more than 500 m ² on any one or more floors	C10MX1-P	C10MX1-C	C10MX1-R

Occupancy Main Type	Occupancy Sub-Type (Refer NBC code Part 4)	Sr. No.	Building Categories	Form Code (FSPA)	Form Code (FSCA)	Form Code (FSCR)
1	2	3	4	5	6	7
		44	Above 15 m but not exceeding 24 m in height	C10MX2-P	C10MX2-C	C10MX2-R
		45	Above 24 m but not exceeding 30 m in height	C10MX3-P	C10MX3-C	C10MX3-R
		46	Above 30 m but less than 100 m in height	C10MX4-P	C10MX4-C	C10MX4-R

TABLE 2: Details of Form Code for referring the checklists and grade of FSO for FSCRe

Occupancy / Main Category Type	Occupancy Sub-Type	Sr. No.	Building Categories	Form Code (FSCRe)	Grade of FSOs*	
1	2	3	4	5	6	
Residential & Lodging	Apartments (Residential)	1	Building Height>15m but less than 25m	C1R1-Re	G, A, S	
		2	Building Height>25m but less than 45m	C1R2-Re	A, S	
		3	Building Height>45m	C1R3-Re	S	
		Dharamshala	4	Building Height>15m	C1R4-Re	A, S
		Hostel	5	Irrespective of area and height	C1R5-Re	G, A, S
		Hotel, Motel	6	Building height<12m, or upto total 30 rooms, or floor area not exceeding 300 m ² on any floor	C1R6-Re	G, A, S
	7		Building height>12m, or more than total 30 rooms, or floor area exceeding 300 m ² on any one floor	C1R7-Re	A, S	
		Starred Hotels	8	Upto 4 Starred Hotels	C1R8-Re	A, S
	9		5 Starred Hotels	C1R9-Re	S	
Educational Institute (Non-Residential part)	Educational (School/College)	10	Building Height >9m but upto 15m	C2ED1-Re	G, A, S	
		11	Building Height >15m but less than 30m	C2ED2-Re	A, S	
		Preschool	12	Building Height >9m	C2ED3-Re	G, A, S
		Coaching Class	13	Building Height >9m	C2ED4-Re	G, A, S
		Training centre	14	Building Height >9m	C2ED5-Re	G, A, S
Institutional (Hospital, Correctional Facility, Care Centers etc.)	Institutional (Mental, Penal Institutions)	15	Building Height upto 15m	C3I1-Re	G, A, S	
		16	Building Height>15m	C3I2-Re	A, S	
		Health (Hospitals)	17	Building Height<15m (plot area upto 1000 m ²)	C3I3-Re	G, A, S
	18		Building Height<15m (plot area more than 1000 m ²)	C3I4-Re	G, A, S	
	19		Building Height>15m and upto24m	C3I5-Re	A, S	
	20		Building Height> 24m	C3I6-Re	S	

Occupancy / Main Category Type	Occupancy Sub-Type	Sr. No.	Building Categories	Form Code (FSCRe)	Grade of FSOs*
1	2	3	4	5	6
Assembly (Permanent Structures like - Cinema Halls, Banquet Halls, Stadium, etc.)	Restaurant	21	Irrespective of area and height	C4A1-Re	G, A, S
	Fitness centre	22	Irrespective of area and height	C4A2-Re	G, A, S
	Community hall	23	Irrespective of area and height	C4A3-Re	G, A, S
	Banquet hall	24	Irrespective of area and height	C4A4-Re	G, A, S
	Town hall	25	Irrespective of area and height	C4A5-Re	A, S
	Auditorium	26	Irrespective of area and height	C4A6-Re	A, S
	Convention centre	27	Irrespective of area and height	C4A7-Re	A, S
	Planetarium	28	Irrespective of area and height	C4A8-Re	A, S
	Stadium	29	Irrespective of area and height	C4A9-Re	A, S
	Museum	30	Irrespective of area and height	C4A10-Re	A, S
	Exhibition hall	31	Irrespective of area and height	C4A11-Re	A, S
	Theatre	32	Irrespective of area and height	C4A12-Re	A, S
	Cinema	33	Irrespective of area and height	C4A13-Re	A, S
	Multiplex	34	Irrespective of area and height	C4A14-Re	A, S
Drive in Cinema	35	Irrespective of area and height	C4A15-Re	A, S	
Business & Offices	Mixed use or Business	36	Building Height>15m or more than G+4	C5B1-Re	A, S
	Corporate offices	37	Building height>9m or more than G+2	C5B2-Re	A, S
	Call centre	38	Irrespective of area and height	C5B3-Re	A, S
Mercantile & Shops	Mercantile	39	Building height>9m or more than G+2	C6M1-Re	G, A, S
	Shopping centre	40	Building height>9m or more than G+2	C6M2-Re	A, S
	Wholesale market	41	Built up area>250 m ²	C6M3-Re	A, S
Storage, Warehouses & parking	Storage Building	42	Built up area>250 m ²	C8S1-Re	S
Hazardous or Flammable Material Storage & handling	Hazardous or Flammable Material Storage & handling	43	Built up area>100 m ²	C9H1-Re	S
Religious Buildings	Religious building (Temple, Mosque, Gurudwara, Church, etc.)	44	Built up area>250 m ²	C10RG1-Re	G, A, S
Fuel Dispensing Facilities	Petrol/Diesel/CNG dispensing pump	45	Irrespective of area and height	C11FD1-Re	A, S

Note: 1. The Checklist for building occupancies covered under THIRD SCHEDULE of the amended Rules, 2021 but not mentioned specifically in this table shall be filled by FSO-Specialist.

2. * FSO- Fire safety officer; *Grade of FSOs: G=General; A=Advance; S=Specialist.

10. Application fees

Application Fees for Fire Safety Plan Approval (FSPA), Fire Safety Certificate Approval (FSCA) and Fire Safety Certificate Renewal (FSCR) shall be paid to concerned Regional Fire Officer or the Chief Fire Officer as per ANNEXURE 8. Application Fees for Fire Safety Plan Renewal of existing building with FSC (FSCRe) shall be as per ANNEXURE 9.

11. Penalty and Appeal**11.1. Penalty**

Penalties to be paid by owner / occupier to the Regional Fire officer or the Chief Fire officer for not submitting the annual declaration, bi-annual declaration, non-renewal of fire safety certificate within prescribed time and for making application for re-issue of the cancelled / rejected FSC shall be as shown in the **TABLE-3** below.

Table 3: Penalties

A	Delay in submitting			Remarks
	Annual declaration* (In Rs.)	Bi-annual declaration cum inspection Report** (In Rs.)	Fire Safety Certificate Renewal (In Rs.)	
1	2	3	4	5
	N × (100% of FSPA Fee)	N × (100% of FSCR Fee)	N × (25% of FSCA Fee)	N=No. of blocks of 90 days
B	Fresh application for issuance of FSCA after it is cancelled / rejected by RFO/CFO			
	25% of FSCA Fee			
<p>*Annual declaration is the declaration to be given by Licensed agency/ owner/ occupier after the issue of Fire Safety Certificate every year till the end of its validity.</p> <p>**Bi-annual declaration is the declaration to be given by fire safety officer/ owner/ occupier after the renewal of Fire Safety Certificate every six month till the end of its validity.</p> <p>Note: Please refer Annexure 8 for FSPA, FSCR and FSCA fees.</p> <p>Illustration:</p> <p>If an owner/occupier delay making an annual declaration by 24 days, then he or she has to pay a late fee equivalent to 100% of FSCA Fee (in case of annual declaration delay) as the delay period is less than 90 days</p> <p>If an owner/occupier delay making an application for renewal by 208 days, then he or she has to pay 3 times of (25% of FSCA fee) as 208 days = 90+90+28 days</p>				

11.2. Appeal

Any appeal against Rejection of an FSPA, FSCA, FSCRe and FSCR application shall lie with the Director, Gujarat State Fire Prevention Services whose decision shall be final. Appeal shall be made in the Web portal <https://gujfiresafetycop.in> within 15 days of the rejection of the relevant application by paying a fee equivalent to 50% of the respective FSPA, FSCA, FSCRe and FSCR application fee to the Director, Gujarat State Fire Prevention Services. In case of failure to make an appeal in this stipulated time, a fresh application needs to be made by the applicant by paying the fees.

12. Clarification and interpretation of the regulations

The Municipal Commissioner in Municipal Corporation area and the Director in other areas of the State shall clarify or interpret provisions of these regulations where it is alleged that there is an error in any order, requirement, decision or determination of fire protection measures made by any Chief Fire Officer or the Regional Fire Officer.

Clarifications or interpretations made by the Municipal Commissioner or the Director, as the case may be, shall be final and binding.

CHAPTER III-PROVISIONS FOR TEMPORARY STRUCTURES AND PANDALS**13. GENERAL**

- 13.1.** Every owner or occupier of such temporary premises or erectors of pandals, to take such fire prevention, fire safety and fire protection measures as may be required under these regulations shall be deemed to be self-regulators for taking fire prevention, fire safety and fire protection measures.
- 13.2.** The erector shall display a declaration to the effect that he or she has taken all the prescribed fire prevention, fire safety and fire protection measures in the “**Form C1**” of the Rules under his/her own signature at a prominent place in the premises, not less than 48 hours before starting to use the premises. The checklist as per **ANNEXURE 10** needs to be filled in the <https://gujfiresafetycop.in> portal by paying the fee of Rs. 2000/- online.
- 13.3.** The fire authority can enter and inspect any temporary structure or pandal about the correctness of the declaration, point out the shortcomings, if any, with directions to remove them within a specified time.
- 13.4.** If the directions of the fire authority are not complied within the time so given, the fire authority may seal the temporary structure or pandal or dismantle such structure or pandal and costs incurred shall be recovered from such defaulter. If the owner or the occupier continues to disobey the directions, the fire authority, may fine the owner or occupier of such temporary premises or erector of pandal up to Rs. 1,00,000/- and for continuing the offence, further fine of Rs. 1,000/- per day.
- 13.5.** Any false declaration filled in form of an online checklist shall be deemed to be a criminal offence punishable under the Indian Penal Code.
- 13.6.** Minimum standards and the measures to be taken for fire prevention and life safety in temporary structures and pandals shall be as per Rules 27 and 31 and as per regulation No. 13 & 14.
- 13.7.** In case where the use of the temporary structure or pandal is meant to attract public gathering, then the owner or the occupier of temporary structure or the erector of the pandal shall submit to the Regional fire Officer or the Chief Fire Officer:-
- a layout plan indicating access to the temporary structure or pandal,
 - the location, dimensions and area of stalls, sanitary facilities and other uses,
 - the plans showing the construction at the sites, if any,
 - a certificate with photograph from a registered electrical engineer to ensure proper load distribution and wiring in case of the temporary structure or pandal having size more than 500sq.mt.,
 - any other plans or documents as may be directed by the Regional fire Officer or the Chief Fire Officer.

14. FIRE PREVENTION, LIFE SAFETY AND FIRE PROTECTION MEASURES**14.1. Basic Requirements:**

- If a temporary structure and pandal is constructed then it shall be of fire resistant material and be open from two sides or provide two emergency exits marked "EMERGENCY EXIT".
- Minimum height of the ceiling of the temporary structure and pandal should not be less than 3.00 meters.
- No structure shall be erected under any live electrical line. It shall be minimum 15 mts away from the railway lines, electrical sub stations, furnaces and other hazardous places. If required, the distance may be increased as directed by the Regional fire Officer or the Chief Fire Officer.
- 4.5 mts margins shall be kept on all sides. Minimum width of the exits of the temporary structure and pandal shall be 2.5 mts.
- All the space used in and outside the public gathering place shall be made into a flat surface and entry/exit shall have a leveled surface without obstruction.
- Kitchens, if any shall be constructed 15 meters away from the temporary structure or pandal and be built by using tin sheets.

- (g) No combustible material like wood shavings, straw, highly inflammable and explosive chemicals and similar materials should be permitted to be stored in the vicinity or inside the temporary structure and pandal.
- (h) No fireworks display with open flames of any kind should be permitted close to the temporary structure and pandal.
- (i) Every security guard and other supporting staff shall have a torch and shall ready all the time during dark hours of operation.

14.2. First-aid firefighting arrangements:

- (a) A 200 liter water barrel along with water buckets/sand buckets shall be placed not more than 50 mts distance.
- (b) Water type, Dry chemical powder and CO₂ type fire extinguishers shall be placed in required numbers at strategic locations.

14.3. Electrical Wiring:

- (a) Electrical wires should pass through PVC conduits and not contact any flammable material. No loose wiring shall be allowed and all ends shall be properly taped and insulated.
- (b) Big lights (halogen/halides) shall be at least 60cms, away from the rides or any metal structure temporarily constructed.
- (c) Heavy cable connections shall be connected by ceramic connectors and then insulated along with the fuses. Power control switches, MCB or ELCB shall be installed for each specific use.
- (d) All light fittings and lamps installed shall not be in contact with cloth or any other flammable material.
- (e) Standby generators of appropriate capacities shall be kept ready at the site in case of pandal having size more than 500sq.mt

14.4. Code of Practice for fire precautionary measures in construction of temporary structures and pandals shall be followed as provided in the IS No. 8758:2013

14.5. Maintaining the minimum standards and to follow the measures to be taken for fire prevention, life safety and fire protection in temporary structures and pandals shall be the liability of every owner or occupier of temporary premises or erectors of pandals.

**CHAPTER IV-PROVISIONS RELATING FIRE PREVENTION AND
LIFE SAFETY MEASURES IN BUILDINGS**

15. Fire Prevention and Life safety measures in buildings:

Requirement of Fire prevention and Life Safety measures in buildings have been specified in checklist. In case of buildings or premises specified in Third Schedule of the Gujarat Fire Prevention & Life Safety Measures Rules 2014 & subsequent amendments but not specifically mentioned in Table-1 of the regulation No. 9.1, the Regional Fire Officer or the Chief Fire Officer may direct to provide these requirements as per the closest building category with such additional equipment and / or specific fire prevention and life safety measures which they deem necessary.

15.1. General requirements

- 15.1.1** The parameters related to Fire prevention and life safety measures i.e., margins, open spaces, staircases, etc. for the buildings/ premises shall be as specified in this regulation and CGDCR 2017 as amended from time to time
- 15.1.2** For high rise building above 15 meters the open space required shall be as per CGDCR.
- 15.1.3** No building shall be erected so as to deprive any other building of the means of access.
- 15.1.4** All fire tender access should be free of encumbrance and shall be motorable.
- 15.1.5** The approach road and open spaces shall be of hard surface capable of taking the weight of Fire engine, weighing upto 22 tons for building less than 15m height, upto 45 tons for building up to 60 m in height and upto 80 tons for building above 60 m in height.

15.2. Construction

15.2.1 Types of Construction: The types of construction according to fire resistance shall be classified in to four Categories, namely, Type 1 construction, Type 2 construction, Type 3 construction and Type 4 construction as per National Building Code of India. The Fire resistance test for structural elements shall be done in accordance with IS-3808. The fire resistance rating of various building components such as wall, columns, beams, floors, etc. shall be as per National Building Code of India.

15.2.2 Steel Framed Constructions: Load bearing steel beams and columns of buildings having total covered area of 500 m² and above shall be protected against failure/ collapse of structure in case of fire. This could be achieved by covering the exposed steel supporting members by suitable fire resistance rated materials like concrete, vermiculite (Hydrous silicate of Aluminum, Magnesian or Iron) etc. as per IS-15103.

15.3. Electrical Installations for fire purposes

15.3.1 Electric cable/wires used shall be of 700 volt grading with Mechanical circuit breaker and earth Leak Circuit Breaker (MCB and ELCB).

15.3.2 Electrical Installations from fire safety point of view shall comply with IS-1646. Use of fire resistance cables and wires. Subject to any of the above regulations every person who undertakes construction of a building and/ or who designs the structural member of the building shall comply with the provisions of National Building Code, Central electricity act prevailing at the relevant time or the provisions of the Indian Standard Specifications published from time to time.

15.3.3 Separate uninterrupted standalone power supply shall be provided directly from the main switch gear panel with circuits laid in separate conduit pipes for emergency services, which include fire pump, sprinkler pump, fire lift and stair case lighting, etc.

15.3.4 Every person who undertakes the construction work on a building or directs or supervises such work shall be responsible and shall ensure use of sound and good quality building materials, properly put together for optimum safety. He shall be liable for all consequences arising out of breach of these regulations.

15.4. Elevators (Lifts)/Escalators

15.4.1 Lift shall be provided in all buildings as prescribed hereunder

15.4.2 The planning and design of lifts including their number, type and capacity depending on the occupancy of the building, the population on each floor based on the occupant load and the building height shall be in accordance with the National building code of India.

15.4.3 In case of Building having height more than 13.0 mts from ground level, lift shall be provided. Lift shall have all the provision of fire life as specified in the National building code of India.

15.4.4 In case of building with 21 meters or more in height, at least two lifts shall be provided. From these lifts at least one of them shall be designed as fire lift as specified in National building code of India.

15.4.5 Lift shall be provided at the rate of one lift for 30 dwelling units of all the floors, or part thereof for residential buildings and at the rate of one lift per 1200.00 Sq.mts. or part thereof of built-up area for non-residential buildings.

15.4.6 The tenement and built-up area on ground floor and two upper floors shall be excluded in computing the above requirement.

15.4.7 Lift shall be provided from ground floor or lower level and shall have minimum capacity of six persons. On the basis of detailed calculations based on the relevant provisions of National Building Code, the number of lifts can be varied.

15.4.8 Minimum internal dimensions for passenger lifts shall be 1500 mm x 1500mm. A clear landing area in front of the lift doors shall be 1800mm x 1800mm and clear opening width of the doors shall be of minimum 900 mm. A handrail of 600 mm length at 1000 mm height from the floor shall be provided.

15.4.9 The time of an automatically closing door should be minimum 5 seconds and the closing speed should not exceed 0.25 m/sec. The interior of the cage shall be provided with a device that audibly indicates the floor the cage has reached and indicates that the door of the cage for entrance/exit is either open or closed.

15.4.10 Maintenance:

- a) The lift installation should receive regular cleaning, lubrication adjustment and adequate servicing by authorized competent persons at such intervals as the type of equipment and frequency of service demand. In order that the lift installation is maintained at all times in a safe condition, a proper maintenance schedule shall be drawn up in consultation with the lift manufacturer and rigidly followed. A log book to record all items relating to general servicing and inspection shall be maintained.
- b) The electrical circuit diagram of the lift with the sequence of operation of different components and parts shall be kept readily available for reference by persons responsible for the maintenance and replacement, where necessary, to the satisfaction of the competent authority.
- c) Any accident arising out of operation of maintenance of the lifts shall be duly reported to the competent authority.

15.5. Exit Requirements

15.5.1 General Exit Requirements:

- a) An exit may be a door way, corridor, passageway(s) to an internal staircase, or external staircase, or to a veranda or terrace(s), which have access to the street, or to roof of a building or a refuge area. An exit may also include a horizontal exit leading to an adjoining building at the same level.
- b) Lifts and escalators shall not normally be considered as exits.
- c) Every exit, exit access or exit discharge shall be continuously maintained free of all obstructions or impediments for full use in the case of fire or other emergency.
- d) Every building meant for human occupancy shall be provided with exits sufficient to permit safe escape of occupants, in case of fire or other emergency.
- e) In every building or structure, exits shall comply with the minimum requirements of this part, except those not accessible for general public use.
- f) No building shall be so altered as to reduce the number, width or protection of less than that required.
- g) Exits shall be clearly visible and the route to reach the exits shall be clearly marked and signs posted to guide the occupants of the floor concerned. Signs shall be illuminated and wired to an independent electrical circuit on an alternative Source of supply. The color of the exit signs shall be green.
- h) The floors of area covered for the means of exit shall be illuminated to values not less than 1 ft candle (10 lux) at floor level. In auditoriums, theatres, concert halls and such other places of assembly, the illumination of floor exit/ access may be reduced during period of performances to value not less than 1/5 ft candle (2 lux)
- i) Fire doors with 2-hour fire resistance shall be provided at appropriate places along the escape route and particularly at the entrance to lift lobby and stairwell where a funnel or flue effect may be created, inducing an upward spread of fire and smoke.
- j) All exits shall provide continuous means of egress to the exterior of a building or to an exterior space leading to a street.
- k) Exits shall be arranged that they may be reached without passing through another occupied unit.

15.5.2 Illumination of means of Exit:

- a) Staircase and corridor light shall conform to the following:
- b) The staircase and corridor lighting shall be the separate circuits and shall be independently connected so that they could be operated by one switch installation on the ground floor easily accessible to firefighting staff at any time irrespective of the position of the individual control of the light points, if any. It should be miniature circuit breaker type of switch so as to avoid replacement of fuse in case of crisis.
- c) Staircase and corridor lighting shall also be connected to alternative supply. The alternative source of supply may be provided by battery continuously trickle charged from the electric mains; and
- d) Suitable arrangement shall be made by installing double throw switches to ensure that the lighting installed in the staircase and the corridor does not get connected. Double throw switch shall be installed in the service room for tenanting the stand- by supply.

15.5.3 External Stairs:

- a) An external staircase is desirable to be provided for high rise buildings and special buildings, if the safe travel distance for exit not maintained. External stairs, when provided shall comply with the following:
- b) External stairs shall always be kept in sound operable conditions.
- c) All external stairs shall be directly connected to the ground.
- d) Care shall be taken to ensure that no wall opening or window opens on to an external stair.
- e) The route to the external stairs shall be free of obstructions at all time.
- f) The external stairs shall be constructed of non- combustible materials and any doorway leading to it shall have the required fire resistance.
- g) No external staircase, used as a fire escape, shall be inclined at an angle greater than 45° from the horizontal.
- h) External stairs shall have straight flight not less than 1250 mm wide with 250 mm treads and risers not more than 190 mm. The number of risers shall be limited to 15 per flight.
- i) Handrail s shall be of height not less than 700 mm and not exceeding 850 - 900 mm. There shall be provisions of balusters with maximum gap of 150 mm.

15.5.4 Horizontal Exits:

- a) The width of horizontal exit shall be same as for the exit doorways.
- b) A horizontal exit shall be equipped with at least one fire/smoke door of minimum 2-hour fire resistance of self-closing type. Further, it should have direct connectivity to the fire escape staircase for evacuation.
- c) Where there is a difference in level between connected areas for horizontal exits, ramps, not more than 1 to 10 slope shall be provided, steps shall not be used.
- d) Doors in horizontal exits shall be open able at all times from both sided.

15.6. Fire Access Stair cases

15.6.1 Staircases to abut on outer wall or be external part of to the building are naturally cross ventilated.

15.6.2 The stairs should not have opening to any part of the building. At least one staircase shall be on external walls of building and shall open directly to the exterior, interior open space or to an open plan of safety. Further, the provision or otherwise of alternative staircases shall be subject to the requirements of travel distance being complied with. It shall be 20 mt. for hazardous use, 25 mt for residential use and 25 mt. for non-residential use.

15.7. Doorways

- 15.7.1** Every exit doorway shall open into an enclosed stairway compartmented from rest of building or a horizontal exit of a corridor or passageway providing continuous and protected means of egress.
- 15.7.2** No exit doorway shall be less than 1000 mm in width except assembly buildings where door width shall be not less than 2000 mm All doorways shall be not less than 2000 mm in height.
- 15.7.3** Exit doorways shall open outwards, that is, away from the room, but shall not obstruct the travel along any exit. No door, when opened, shall reduce the required width of stairway or landing to less than 900 mm. Overhead or sliding doors shall not be installed.
- Note: In the case of building where there is a central corridor, the doors of rooms shall open outward and flush to the wall to permit smooth flow of traffic in the corridor.*
- 15.7.4** Exit door shall not open immediately upon a flight of stairs. A-landing equal to at least the width of the door (not less than 900mm) shall be provided in the stairway at each doorway, The level of landing shall be the same as that of floor, which it serves. Manual door should incorporate kick plate 300 mm high to withstand impact of wheelchair footrest where doors are glazed. Door handle and locks should be positioned between 900-1000 mm from floor level.
- 15.7.5** Exit doorways shall be open able from the side, which they serve without the use of a key (panic bar).
- 15.7.6** Mirrors shall not be placed in exit doors to avoid confusion regarding the direction of exit.

15.8. Corridors and passageways & Stairs

- 15.8.1** Flight: -No flight shall contain more than 12 to 16 risers, but in residential buildings, in narrow plots and in high density Housing a single flight staircase may be permitted.
- 15.8.2** Risers: - The maximum height of a riser shall be 19cm. in a residential building and 16 cm. in any other occupancy. However, on an internal stairway within a dwelling unit a riser may be 25 cm high.
- 15.8.3** Treads: - The minimum width of the tread without nosing shall be 25 cm. for staircase of a residential building, other than fire escapes. In other occupancies the minimum width of the tread shall be 30 cm. It shall have a non-slippery finish and shall be maintained in that fashion.
- 15.8.4** Head room: The minimum head room in a passage under the landing of a staircase under the staircase shall be 2.2 m.
- 15.8.5** Floor indicator: The number of each floor shall be conspicuously painted in figures at least 15 cm large on the wall facing the flight of a stairway or at such suitable place as is distinctly visible from the flights.
- 15.8.6** Hand Rail: Hand rail a minimum height of 0.9 m. from the center of the tread shall be provided.
- 15.8.7** For all residential and non-residential building except individual detached building minimum clear width of lobbies or corridor shall be as per CGDCR.
- 15.8.8** In case of any building having height more than 15.0mt and no provision of natural ventilation on either side of corridor, in such building, smoke exhaust system having make-up air and exhaust air system or alternatively, pressurization system with supply air system shall be required for the exit access corridors.

15.9. Internal/additional staircases

- 15.9.1** Additional stairs shall be constructed of non-combustible materials throughout.
- 15.9.2** A staircase shall not be provided around a lift shaft unless provided with fire stop door of 1 hour rating at every floor level and no other openings in the inside walls
- 15.9.3** Hollow combustible construction shall not be permitted.

- 15.9.4** No gas piping, electrical panels & appliances or AC ducts shall be allowed in the stairway. However, service shafts/ ducts may be permitted. Electrical Shafts/ ducts shall have not less than 2-hour fire resistance. For other service shafts/ ducts, the fire resistance shall be not less than 1 hour.
- 15.9.5** Electric meters shall not be located below the staircase or along the exit route. Electric meters room shall be adequately ventilated & easily accessible.
- 15.9.6** Notwithstanding the detailed provision for exits, the following minimum width shall be provided for staircases-

Type of Occupancy	Width of Internal stair in mts
Residential building, Hotel building, educational building, Institutional buildings, (i.e., hospital), Mercantile, business, storage industrial, hazardous, buildings.)	
Height upto 25m	1.2
Heights > 25m	2.0
Assembly buildings	2.0
Note: -	
a. In case of low-rise apartment type building, minimum stair width for more than 6 tenements on each floor shall be 1.5mts.	
b. No winders shall be allowed except in case of individual dwelling unit	

- 15.9.7** The minimum width of tread without nosing shall be 250 mm for internal staircase of residential buildings, other than fire escapes. This shall be 300 mm for assembly, hotels, educational, institutional, business and other buildings. The treads be constructed and maintained in a manner to prevent slipping.
- 15.9.8** The maximum height of riser shall be 190 mm for residential buildings and 160 mm for other buildings and the number shall be limited to 12 per flight.
- 15.9.9** Continuous handrails shall be provided on both sides including the wall (if any) at two levels: upper at 850 mm - 900 mm and lower at 700 mm to be measured from the base of the middle of the treads to the top of handrails. Balusters/ Railing shall be provided in such a way that the width of staircase does not reduce. The maximum gap between balusters shall be 150 mm.
- 15.9.10** All steps, edges must have a contrasting color band of 50 mm width stretched entirely across the step width for uses other than residential use.
- 15.9.11** Soffit (underside /open area under the stairs) of the stairs and ramps should be enclosed or protected with rails or raised curbs or marked with a tactile surface
- 15.9.12** The design of staircase shall also take into account the following:
- The minimum headroom in a passage under the landing of a staircase and the stair shall be 2.2 m.
 - No living space, store or other fire risk shall open directly into the staircase or staircases.
 - External exit door of staircase enclosure at ground level shall open directly to the open spaces.
 - The main and external staircases shall be continuous from ground floor to the terrace level.
 - Lifts shall not open in staircase.
 - No combustible material shall be used for decoration/ wall paneling in the staircase.

- 15.9.13** Beams/ columns and other building features shall not reduce the head room/ width of the staircase.
- 15.9.14** The exit way with arrow indicating the way to the escape route shall be provided at a height of 1.8 m from the floor level on the wall and shall be illuminated by electric light connected to corridor circuits. All exit way marking signs should be flush with the wall and so designed that no mechanical damage shall occur to them due to moving of furniture or other heavy - equipment. Further, all landings of floor shall have floor indicating the number of floors as per byelaws. The floor indication board shall be placed on the wall immediately facing the flight of stairs and nearest to the landing. It shall be of size not less than 0.5 m x 0.5 m.
- 15.9.15** Individual floors shall be prominently indicated on the wall facing the staircases.
- 15.9.16** In case of single staircase, it shall terminate at the ground floor level and the access to the basement shall be by a separate staircase.

15.10. Cellar

- 15.10.1** In a building unit, the cellar may be permitted on the following conditions:
- a) Clear width of the stair leading to the cellar shall not be less than the width of the regular staircase leading to upper floors.
 - b) No stairs to be constructed under these regulations shall consist of any wooden material.
 - c) Adequate opening for ventilation should be provided as directed by Competent Authority. The materials of the construction and fixtures of the cellar should be of fire resisting nature and in no case; wood shall be used as structural part of the cellar or any fixtures thereof. The extent of ventilation shall be the same as required by the particular occupancy for which the basement is used. Any deficiency must be made well by resort to a mechanical system, viz. blowers, exhaust fans, air conditioning system, according to the standards in National Building Code of India.
- 15.10.2** Uses Permitted: -
- a) For all buildings: Parking, safe deposit vault, A.C. Plant, Grey water treatment plant, Sewage Treatment Plant, water tank, storage other than inflammable material, non-habitable use.
 - b) For Hospitals exceeding 2000 Sq.mts of built-up area — As mentioned in (a) above, Radiation-production device, Radiation Therapy room, MRI or X-Ray room, laundry and housekeeping.
 - c) For Malls and/or exceeding 2000 Sq.mts of built-up area - As mentioned in (a) above, Security Cabin, Electric Cabin, General room, boiler room, laundry, housekeeping, store, lockers, rest room and communication room separated by brick masonry walls of at least 230 cm.
Note: Total cumulative built-up area for above listed usage shall not exceed 25% of the basement area. However, no kind of any transformer shall be permitted in cellar / basement or within the building.
 - d) Staircase at a distance of different occupancies shall have to be provided to reach the lower most floor of the cellar.
 - e) Stairs in the basement shall only lead to the ground or first floor. It shall not lead to upper floors so that it becomes a part of the staircase leading to the terrace of the building.
 - f) In a building unit where more than two lifts are required to-be-provided as per this regulation, minimum two lifts shall be provided to reach the lower most level of the cellar.

15.11. Ramps

15.11.1 Ramp for basement or storied parking: - For parking spaces in a basement and upper at least two ramps of adequate width and slope shall be provided preferably at the opposite end. Such ramps may be permitted in the side and rear marginal open spaces, after leaving sufficient space for movement of firefighting equipment.

15.11.2 Ramp shall be 1:15 gradient.

15.11.3 Minimum outer turning Radius shall be 12 mt. and minimum inner turning radius shall be 8.5 mt. as per below given table:

Requirements	
Minimum Gross Operational weight	30 Tonne
Minimum Overhead Clearance	4.5 mt
Minimum Width of Fire Appliance Accessway	3.5 mt
Minimum Width of Perimeter Vehicular Access for Large Isolated Building.	6.0 mt
Minimum Lateral Clearance	2.0 mt
Hardstanding.	6.0mwidex15.0mlong
Minimum Turning Circle Kerb /Kerb	24.0 mt
Minimum Turning Circle Wall /Wall	28.0 mt
Maximum Dead-end	45.0 mt
Maximum Gradient	1:15

15.12. Ramp for Fire Tender

15.12.1 For parking except basement/s, hollow plinth at ground level and ramp leading to parking above ground level at any floor shall be permissible in side/rear margin are subject to any site/building unit which fulfills following minimum requirement in case of building height exceeds 25 mt.

15.12.2 Turning Facilities: Length of fire appliance accessway at dead-ends shall not exceed 45mt and shall not be less than 15mt. If exceeding 45mt, then turning facilities at the dead end (a turning circle or a hammerhead) must be - provided as shown in Figure below.

15.12.3 The outer radius for turning in an access way and fire appliance access road shall comply with the requirements noted in Figure below.

(a) Turning facility for fire appliance

(b) U-turn facility for fire appliance

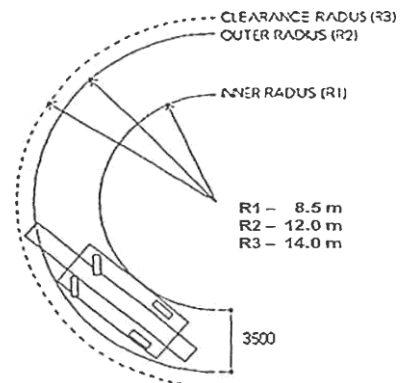
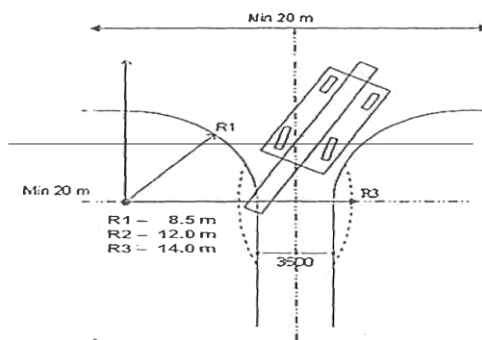

15.13. Loft

The loft at a minimum height of 2.1 mts. from floor level not exceeding 30% floor area of the room may be allowed in any room.

15.14. Control of development on terrace and basement/cellar

15.14.1 No development, including use, shall be permitted on the terrace & basement space which is located at egress of the stair leading to terrace should be kept open. Storage in such space either temporary or permanent shall not be permitted

15.14.2 Uses permitted: - parking, safe deposit vault, A.C. Plant, storage other than inflammable material. MRI or X-Ray room in hospital.

15.14.3 For all buildings: Parking, safe deposit vault, A.C. Plant, Grey water treatment plant, Sewage Treatment Plant, water tank, storage other than inflammable material, non-habitable use.

15.14.4 For Hospitals exceeding 2000 Sq.mts of built-up area — As mentioned above, Radiation-production device, Radiation Therapy room, MRI or X-Ray room, laundry and housekeeping.

15.14.5 For Malls and/or exceeding 2000 Sq.mts of built-up area - As mentioned above, Security Cabin, Electric Cabin, General room, boiler room, laundry, housekeeping, store, lockers, rest room and communication room separated by brick masonry walls of at least 230 cm.

Total cumulative built-up area for above listed usage shall not exceed 25% of the basement area. However, no kind of any transformer shall be permitted in cellar / basement or within the building.

15.15. Emergency and escape lighting

15.15.1 The emergency lighting shall be provided to be put on within 5 second of the failure if the normal lighting supply and shall be of independent of main supply.

15.15.2 Escape lighting luminaries should be sited to cover the following locations:

- a) At each exit door,
- b) Near each staircase so that each flight of stairs receives direct light,
- c) Near any other change of floor level,
- d) Outside each final exit and close to it,
- e) Near each fire alarm call point,
- f) Near firefighting equipment and,
- g) To illuminate exit and safety signs as required by the enforcing authority.

*Note: * For the purpose of this clause 'near' is normally considered to be within 2m measured horizontally.*

15.15.3 Emergency lighting systems shall be designed to ensure that a fault or failure in any one luminary does not further reduce the effectiveness of the system.

15.15.4 The luminaries shall be mounted as low as possible, but at least 2m above the floor level.

15.15.5 Sign are required at all exits, emergency exits and escape routes, which should comply with the graphic requirements of the relevant Indian standards.

15.15.6 Emergency lighting luminaries and their fitting shall be fire resistance type.

15.15.7 It is essential that the wiring and installation of the emergency lighting systems are of high quality so as to ensure their perfect serviceability at all times.

15.15.8 The emergency lighting system shall be capable of continuous operation for a minimum duration of 1 hour and 30 minutes.

15.15.9 The emergency lighting system shall be well maintained by periodical inspections and tests so as to ensure their perfect serviceability at all times.

15.15.10 Electric supply for fire pump/fire lift shall be provided separately and not get switched off along with the main supply of building.

15.15.11 Electrical services:

- a) These shall conform to those given in Part 4 NBC and the IS:1646 and particular attention is drawn to the following:
- b) The electric distribution cable/wiring shall be laid in a separate duct. The duct shall be sealed at every floor with non-combustible materials having the same fire resistance as that of the duct. Low and medium voltage wiring running in shaft and in false ceiling shall run in separate conduits.
- c) Separate circuits for firefighting pumps, lifts, staircases, corridor lighting and blowers for pressurizing system shall be provided directly from the main switch gear panel and these circuits shall be laid in separate conduit pipes, so that fire in one circuit will not affect the others. Such circuits shall be protected at origin by an automatic circuit breaker with its no-volt coil removed. Master switches controlling essential service circuits shall be clearly labelled.
- d) An independent and well-ventilated electrical service room shall be provided on the ground level or first basement with direct access from outside or from the corridor for the purpose of termination of electric supply from the licensee's service and alternative supply cables. The doors provided for the service room shall have fire resistance of not less than 2 hours.
Note: If service room is located at the first basement, it should have automatic fire extinguishing system
- e) Suitable circuit breakers shall be provided at the appropriate points.

15.15.12 Emergency Power Supply Emergency power supply shall be as per National Building code of India.

15.16. Lighting / Electrical Protection

15.16.1 The lighting protection for buildings shall be provided as given in National Building Code of India.

15.16.2 The lighting protection for buildings shall be provided as given in National Building Code of India.

15.16.3 A lightning arrester should also be installed and be properly earthed to prevent damage to the building when the lightning strikes.

15.17. Smoke & Fire venting

15.17.1 The provisions for smoke and fire venting for industrial buildings with large floor areas shall conform to regulations given in Part 4 National Building Code of India, shall be provided for special buildings and for hotel and hospital building more than 25 m height.

15.17.2 The provisions for smoke and fire venting for industrial buildings with large floor areas shall conform to regulations given in Part 4 National Building Code of India.

15.18. Ventilation:

15.18.1 All enclosures should have openable windows and vents to be opened in case of fire or smoke accumulation.

15.18.2 If the floor or the building is centrally air-conditioned then a provision to stop the air handling unit should be provided and it shall be blocked by a damper and the same air duct should act as smoke extractors with the extraction fan switching on automatically, if a fire or smoke is detected.

- 15.18.3** Ventilation from the Top and Skylight etc.: - Where an open well for light and ventilation, within the space enclosed by a stairway and its landings, is proposed to be provided, the least horizontal dimensions of which are equal to two times the width of the staircase. A ventilating skylight with provided fixed or movable louvers to the satisfaction of the competent Authority. The glazed roof of the skylight shall not be less than 3.7 sq. mts. in area. No lift or any other fixture shall be erected in such staircase well.
- 15.18.4** Ventilation in staircase: all the stair cases should have openings in a manner that appropriate cross ventilation on each floor is maintained. No such ventilation shall be covered by facade which would obstruct the ventilation. Specifically, when glass facade is provided, they shall be provided in such a manner that the cross ventilation is available.
- 15.18.5** The provisions for ventilation shall conform to requirements given in Part 4 National Building Code of India

15.19. Evacuation Route Plan

- 15.19.1** Applicant shall, along with the application for development permission, submit the plan showing the evacuation route comprising of following: -
- a) Route for vertical and horizontal movement.
 - b) Width of the Corridor, Stair, provided that, flight length calculated in each number of steps, width and length of landing shall comply these regulations.
 - c) Staircase details showing the ventilation for air movement and illumination complying the provisions of these regulations.
 - d) Exit Plan as per exit requirements under these regulations.
 - e) Emergency exit route plan framed in glass case shall be displayed in the common corridor, cross passages, staircase/lift lobbies of each floor level.

15.20. Service Ducts/Shafts

- 15.20.1** Electrical shafts/ducts shall have not less than 2hours fire resistance and for other services shafts/ducts, the fire resistance shall be not less than 1 hour. All such ducts/ shafts shall be properly sealed and fire stopped at all floor levels.
- 15.20.2** A vent opening at the top of the service shaft shall be provided having between one - fourth and one- half of the area of the shaft.
- 15.20.3** Refuse chutes shall have opening at least 1 m above roof level for venting purpose and they shall have an enclosure wall of non-combustible material with fire resistance of not less than 2 hours. They shall not be located within the staircase enclosure or service shafts, or air-conditioning shafts. Inspection panel and doors shall be tight fitting with 1 hour fire resistance; the chutes should be as far away as possible from exits.

15.21. Air Conditioning

- 15.21.1** Escape routes like staircases, common corridors, lift lobbies, etc., shall not be used as return air passage.
- 15.21.2** The ducting shall be constructed of substantial gauge metal as per IS: 655- Specification for Metal Air Ducts.
- 15.21.3** Wherever the ducts pass through firewalls or floors, the opening around the ducts shall be sealed with materials having fire resistance rating of the compartment.
- 15.21.4** The materials used for insulating the duct system (inside or outside) shall be of non-combustible material. Glass wool shall not be wrapped or secured by any material of combustible nature.
- 15.21.5** The air-handling units shall be separate for each floor and air ducts for every floor shall be separate and in no way interconnected with the ducting of any other floor.

- 15.21.6** If the air-handling unit serves more than one floor, the conditions given below shall be complied in addition to the recommendations above.
- 15.21.7** Proper arrangements by way of automatic fire dampers, working on fusible link/or smoke detector principle for isolating all ducting at every floor from the main riser, shall be made.
- 15.21.8** When the automatic fire alarm operates, the respective air-handling units of the air-conditioning system shall automatically be switched off.
- 15.21.9** Where plenum is used for return air passage, ceiling and its fixtures shall be of non-combustible material.
- 15.21.10** The provisions for Air conditioning shall conform to requirements given in Part 4 National Building Code of India

15.22. Compartmentation

As far as Compartmentation in the buildings/ premises is concern, the provisions of National Building Code of India (Part 4) shall be considered.

15.23. Sub-stations

- 15.23.1** The sub-station shall have separate fire resisting walls/surroundings and shall necessarily be located at the periphery of the floor having separate access preferably from fire escape staircase.
- 15.23.2** The outside walls, ceiling and floor including doors and windows to the sub-station area shall be of 2 hours fire rating.
- 15.23.3** A sub-station or a switch-station with oil- filled equipment must not be located in the building. When housed inside the building, The transformer shall be of premises by walls/doors/cut outs having fire resistance rating of 4 hours.
- 15.23.4** The Sub-Station area needs to be maintained at negative air pressure and area in substation shall not be used as storage/dump areas.
- 15.23.5** No transformer shall be allowed inside the building.
- 15.23.6** Substation to be provided at rear corner of a building unit after leaving enough open space around the building for firefighting requirements.

15.24. Boilers and Boiler Rooms

- 15.24.1** The boiler shall be installed in a fire resisting room of 4 hours fire resistance rating, and this room shall be situated on the periphery of the building and in no case in basement, dyke shall be provided at the lower level.
- 15.24.2** Fire brigade inlets shall be provided on the external walls of the building near the ground level to enable the fire services.

15.25. Fire Control Room

- 15.25.1** For building height having more than 45m and floor area 3000 sq.mt and more on each floor, there shall be a control room on the entrance floor of the building with communication system (suitable public address system) to all floors and facilities for receiving the message from different floors. Details of all floor plans along with the details of firefighting equipment and installations shall be displayed in the fire control room. The fire control room shall also have facilities to detect the fire on any floor through indicator board's connection; fire detection and alarm system on all floors. The fire staff in charge of the fire control room shall be responsible for maintenance of the various services and the firefighting equipment and installations in coordination with security, electrical and civil staff of the building.
- 15.25.2** In case of Institutional building, Fire Control room shall be provided for height more than 15 meters.

15.26. Fire Lifts

- 15.26.1** Each building should have at least one lift as a Fire- lift and if the building is divided into two or more parts then each part should have a Fire-lift.
- 15.26.2** Lift-well should have blowers to pressurize the lift-well so connected that it will automatically operate when alarm call point is operated, so that it prevents the lift well getting smoke logged.
- 15.26.3** To enable fire services personnel to reach the upper floors with the minimum delay, one fire lift per 1200 m² of floor area shall be provided and shall be available for the exclusive use of the firemen in an emergency.
- 15.26.4** The lift shall have a floor area of not less than 1.4 m². It shall have loading capacity of not less than 545 KG (8 persons lift) with automatic closing doors of minimum 0.8m width.
- 15.26.5** The electric supply shall be on a separate service from electric supply mains in a building and the cables run in a route safe from fire, that is, within the lift shaft. Lights and fans in the elevators having wooden paneling or sheet steel construction shall be operated on 24-volt supply.
- 15.26.6** Firefighting lift should be provided with a ceiling hatch for use in case of emergency.
- 15.26.7** In case of failure of normal electric supply, it shall automatically change over to alternate supply. For apartment houses, this changeover of supply could be done through manually operated changeover switch. Alternatively, the lift shall be so wired that in case of power failure, it comes down at the ground level and comes to stand-still with door open.
- 15.26.8** The operation of fire lift should be by a simple toggle or two -button switch situated in glass-fronted box adjacent to the lift at the entrance level. When the switch is on, landing call points will become inoperative and the lift will be on car control only or on a priority control device. When the switch is off, the lift can be used by the occupants in normal times.
- 15.26.9** The words 'Fire Lift' shall be conspicuously displayed in fluorescent paint on the lift landing door at each floor level.
- 15.26.10** The speed of the fire lift shall be such that it can reach the top floor from ground level within one minute.

15.27. Refuge Area

- 15.27.1** Following provisions shall apply:
- Refuge area shall be provided on the external walls/ periphery of the floor preferably on a cantilever projection, open to air at least on one side, protected with suitable railings and shall have direct access to fire ladder.
 - Minimum area of 15 m² on external wall with minimum width of 0.75 m at every 18 m height; for floor area up to 1000 m²
 - If floor area 1000 m², another Refuge Area on another end of the floor.
 - For floors above 25 m and up to 39m-One refuge area on the floor immediately above 25 m.
 - For floors above 39 m -One refuge area on the floor immediately above 39 m and so on after every 15 m.

Note:- Residential flats in multistoried buildings with balcony need not be provided with refuge area, however flats without balcony shall be provided with refuge area as given above.

15.28. Basement

- 15.28.1** These shall conform to those given in Part 4 National Building Code of India and particular attention is drawn to the following:
- 15.28.2** The staircase of basements shall be of enclosed type having fire resistance of not less than 2 hours and shall be situated at the periphery of the basement to be entered at ground level only from the open air and in such position that smoke from any fire in the basement shall not

obstruct any exit serving the ground and upper storey of the building. It shall communicate with basement through a lobby provided with fire resisting self-closing doors of one hour resistance. If the travel distance exceeds the desired level, additional staircases shall be provided at proper places. The basement shall not open in to the staircase or lift well directly. If so then it has to be protected by 2 hours fire resistant self-closing doors,

- 15.28.3** The basement shall be provided with natural ventilations and more than one basement shall have mechanical extractors for smoke venting shall be designed to permit 6 changes per hour in case of fire or distress call. For normal operations, air changes schedule shall be as per National Building Code of India.
- 15.28.4** Discharge apparatus of all natural draft smoke vents shall be so arranged as to be readily accessible for opening by fire service personnel.
- 15.28.5** Use of basement for kitchen shall not be permitted. Building services such as, boiler rooms in basement shall comply with the provisions of the IE Act/ Rules.
- 15.28.6** The basement of 200 sq. meters or more shall be protected with provisions of Part 4 National Building Code of India
- 15.28.7** Each basement shall be separately ventilated. First basement to be naturally ventilated @ 2.5% of the ceiling area. Other basements shall be mechanically ventilated.

15.29. Terrace drainage

In all non-residential buildings for the effective drainage of water which is likely to accumulate when the event of fire the drainage should be design for double the capacity what would have been required as per the CGDCR.

15.30. Materials for interior decoration

Only material s conforming to class 1 flame spread classification as per IS 12777 shall be used. Materials which are combustible in nature and may spread toxic fumes/gases shall not be used for interior decoration/furnishings etc.

15.31. Electrical installations

- 15.31.1** The planning, design and installation of electrical installation, air-conditioning and heating work shall conform to the provisions of National building code of India.
- 15.31.2** Separate uninterrupted standalone power supply shall be provided for emergency services, which includes fire pump, sprinkler pump, fire lift, staircase lighting.

15.32. Fire Check Floor/ Fire Cut off Floor

- 15.32.1** A high-rise building having height more than 70 m shall be provided with fire check floor (entire floor) above 70 m at immediate habitable floor level.
- 15.32.2** The fire check floor shall not be used for any purpose and it shall be the responsibility of the owner/occupier/ registered society to maintain the same clean and free of encumbrances and encroachments at all times. Drinking water facility and toilet facility shall be provided.
- 15.32.3** Periphery of the Fire Check floor shall not be enclosed.
- 15.32.4** Fire Drenchers shall be provided at the periphery of each fire check floor externally.
- 15.32.5** Fire Check Floor/ Fire Cut off Floor shall be free of FSI.

15.33. Glass facades

- 15.33.1** In addition to the National building code of India (Part 4), following regulations shall also be applicable;
- 15.33.2** No glass facades shall be permitted in School and Hospital buildings.
- 15.33.3** The distance between building structure and glass facade must not be more than 300 mm.

- 15.33.4 To restrict spread of fire, there must be an automatic water curtain system on each floor.
- 15.33.5 Each ceiling must have a pop-up vent, which can be easily reached from the floor, to be integrated with the smoke detection system.
- 15.33.6 All glass walls must not have any coating of combustible materials like plastic, and must be designed to resist fire for at least 2 hours.
- 15.33.7 The glazing used for the facade shall be of toughened (tempered) safety glass as per IS:2553.
- 15.33.8 No glass façade shall be permitted at the external face of the staircase.
- 15.33.9 Every floor must have a two-way opening measuring 1.5m×1.5m in the wall, as access points for rescue workers. They must properly label as "Emergency Exit."
- 15.33.10 Glass facade for high rise building shall be of 1 hour fire resistance.

CHAPTER V- SPECIAL PROVISIONS RELATING TO FIRE PREVENTION AND LIFE SAFETY MEASURES FOR SPECIAL BUILDINGS

16. General:

The building with height restriction under the National Building code of India but is permissible under the CGDCR may be permitted subject to the permission of the High-Level Technical Committee (HLTC) constituted by the Government. The FSPA shall be issued only after the recommendations of the HLTC.

17. Buildings of Height more than 15 meters up to 25 meters (From ground level to top floor ceiling height):

17.1 Staircase

- 17.1.1 If the lifts and staircase from higher floors go directly to the basement then this area shall be protected by 1 hour fire resistance construction including fire doors subject to opinion and requirement of local fire authority in specially designed building have to be considered and observed.
- 17.1.2 Staircase: For above 15 meters up to 25 meters height (excluding parapet wall, lift and stair cabin, OH tank)
- 17.1.3 Width of staircase: 1.5 meter clear inside to inside
- 17.1.4 If a centrally located staircase is provided with pressurization and fire-resistant doors, the central staircase shall be in addition to the ventilated staircases require for the floor area, maintaining the travel distance.

17.2 Electrical duct

Electrical duct should have sealed metal doors with metal frame or fire rated doors at each floor level. Opening of the duct shall be from basement to terrace level.

17.3 Hollow plinth

Hollow plinth parking shall be protected with sprinklers as per Indian standard IS 15105.

17.4 Margins

All margins shall be as per CGDCR.

17.5 Ramp

Ramps shall be provided as per CGDCR.

18. Buildings of Height more than 25 meters up to 45 meters (From ground level to top floor ceiling height):

18.1 Staircase

- 18.1.1 For Buildings up to 45 meters (excluding parapet wall, lift and stair cabin, OH tank) & each floor area more than 3000 sq. meters- ventilated from two sides/cross ventilated/external staircases connected through a lobby-travel distance not to exceed 25 meters.

18.1.2 If a centrally located staircase is provided with pressurization and fire-resistant doors, the central staircase shall be in addition to the ventilated staircases require for the floor area, maintaining the travel distance.

18.1.3 Width of staircase shall be 2 meters width for all buildings.

18.1.4 If the lift and staircase from higher floors go directly to the basements then this area shall be protected by 2 hours fire resistant construction including fire doors.

18.2 Lift

One Fire lift for each 1200 Sq. meters of floor area on each level.

18.3 Electrical duct

Electrical duct should have sealed metal doors with metal frame or fire rated doors at each floor level. Opening of the duct shall be from basement to terrace level.

18.4 Hollow plinth

Hollow plinth parking shall be protected with sprinklers as per Indian standard IS 15105.

18.5 Margins

All margins shall be as per CGDCR.

18.6 Ramp

Ramps shall be provided as per CGDCR.

18.7 Refuge area

Refuge area shall be provided as per CGDCR.

19. Buildings of Height more than 45 meters up to 70 meters (From ground level to top floor ceiling height):

19.1 Staircase:

19.1.1 For more than 45 meters (excluding parapet wall, lift and stair cabin, OH tank) & each floor area more than 3000 sq. meters- ventilated from two sides/cross ventilated/external staircases connected through a lobby-travel distance not to exceed 25 meters.

19.1.2 If a centrally located staircase is provided with pressurization and fire-resistant doors, the central staircase shall be in addition to the ventilated staircases require for the floor area, maintaining the travel distance.

19.1.3 Width of staircase shall be 2 meters width for all buildings.

19.1.4 The staircase shall be of RCC construction & ventilated and shall be kept open except the parapet wall, all the space above the parapet wall shall be kept open.

19.1.5 The staircase shall be designed/ located at the exterior part of the building. If the staircase is in the center of the building and is not ventilated then a fire escape staircase (fire tower) has to be installed on either side of the building with travel distance not more than 30 meters.

19.2 Lift

If the lift and staircase from higher floors go directly to the basements then this area shall be protected by 2 hours fire resistant construction including fire doors.

19.3 Fire lift

19.3.1 One fire lift for each 1200 sq. meter area of floor area on each level (Fire lift otherwise can be used as a common passenger lift).

19.3.2 All lifts of the building shall be Fire lifts and shall have a provision to ground in case of electrical failure and shall be installed with a panic button and a talk-back system. The lift shall not be installed in the center of the building and the lift shaft shall be ventilated from the top with smoke extractors. The lift for the higher floors shall end at the ground level and not go to the basement

19.4 Electrical duct

Electrical duct should have sealed metal doors with metal frame or fire rated doors at each floor level. Opening of the duct shall be from basement to terrace level.

19.5 Hollow plinth

Hollow plinth parking shall be protected with sprinklers as per Indian standard IS 15105.

19.6 Margins

All margins shall be as per CGDCR.

19.7 Ramp

Ramps shall be provided as per CGDCR.

19.8 Refuge area

Refuge area shall be provided as per CGDCR.

19.9 Electric supply

19.9.1 Electric supply to the Fire pumps, fire lift all shall be supplied parallel (standalone) to the building supply and should not get cut-off if the supply to the building is switched off.

19.9.2 All the electric wiring used shall be of 900 volt grading and connected to each enclosure through a MCB for a particular load.

19.10 Auto glow signage

All exits, corridors and staircase shall have auto glow signs for people to escape in case of fires in darkness. Even the floors shall have guide marks guiding towards the staircase.

19.11 Ventilation

19.11.1 Ventilation of stair-cases:

Every stair case provided under the foregoing clauses shall be lighted and ventilated to the satisfaction of the Authority from an open-air space not less than 1 sq.mt.

19.11.2 Windows in stair-case Bay:

There shall be provided a window or windows of an aggregate area of at least 1.2 sq. meters on each storey in such of the wall of the stair-case room which abuts on such 1 sq.mt. open air space to right and ventilate such staircase.

19.12 Skip floor/Refuge area

Skip floor/Refuge area shall be provided as per CGDCR.

20. Buildings of Height more than 100 meters (From ground level to top floor ceiling height):

The Fire prevention, Life safety and Fire protection measures shall be provided as per this regulation and CGDCR 2017 along with the subsequent notifications.

21. Mixed Occupancy:

CGDCR shall be followed for the provisions related to Fire prevention and life safety measures in addition to the provisions under the regulations.

22. Institutional buildings:

22.1 CGDCR shall be followed for the provisions related to Fire prevention and life safety measures in addition to the provisions under the regulations.

22.2 In case of standalone institutional buildings/ premises minimum two staircases with width not less than 2 m shall be provided.

23. Storage Buildings:

23.1 These shall conform to those given in Part 4 of National Building Code of India.

23.2 Storage Buildings beyond 15 meters height shall not be permitted. However, building used for Car Park may be permitted beyond 15 meters.

24. Hazardous Building:

24.1 These shall conform to those given in Part 4 of National Building Code of India.

24.2 Hazardous Buildings beyond 15 meters height shall not be permitted. However, building used for Car Park may be permitted beyond 15 meters.

25. Assembly Building:

25.1 Railway station including Metro stations buildings, bus stations building, sea port building, Airport building and other public gathering buildings shall be considered as an assembly building according to the national building code of India and provisions related to fire prevention, life safety and fire protection, shall follow as per this regulation, CGDCR, their respective govt. norms.

25.2 Beam smoke detectors installed across the assembly building.

25.3 The material used for seats and lining shall be of Fire-resistant material.

25.4 The foyer and the halls shall have emergency lights operating automatically in case of electricity failure.

25.5 The projection room shall have suitable Fire extinguishers and shall have doors on two extreme sides.

CHAPTER VI-PROVISIONS RELATING FIRE PROTECTION MEASURES IN BUILDINGS**26. Applicability of National Building code of India (Part 4) and CGDCR**

26.1 Fire Protection measures for the buildings/ premises specified in Third Schedule of the Gujarat Fire Prevention & Life Safety Measures Rules 2014 & subsequent amendments, shall be regulated as per the National Building Code of India (Part 4 Fire & Life Safety) and accordingly the Checklists are prepared as mentioned in regulation no. 9. Relevant Checklist as per the occupancy type needs to be filled in the web portal <https://gujfiresafetycop.in> at the time of making application.

26.2 Requirement of hydrants, wet riser, sprinkler system and special fire protection system have been specified in checklists. In case of buildings or premises specified in Third Schedule of the Gujarat Fire Prevention & Life Safety Measures Rules 2014 & subsequent amendments but not specifically mentioned in Table-1 of the regulation No. 9.1, the Regional Fire Officer or the Chief Fire Officer may direct to provide these requirements as per the closest building category with such additional equipment and / or specific fire protection systems which they deem necessary.

26.3 The Fire protection systems shall be designed, installed and maintained as per the relevant Indian Standards and amendments issued time to time. An indicative not comprehensive list of Indian standards is as follow:

1. IS 3844- Code of practice for installation and maintenance of internal fire hydrants and hose reels on premises
2. IS 13039- External hydrant systems - provision and maintenance - Code of practice
3. IS 15105- Design and Installation of Fixed Automatic Sprinkler Fire Extinguishing Systems - Code of Practice
4. IS 2189- Selection, Installation and Maintenance of Automatic Fire Detection and Alarm System Code of Practice
5. IS 2190- Selection, installation and maintenance of first-aid fire extinguishers — code of practice
6. IS 15683- Portable fire extinguishers - Performance and construction

7. IS 15325- Design and Installation of Fixed Automatic High and Medium Velocity Water Spray System - Code of Practice
8. IS 884- First-Aid Hose Reel for Fire Fighting
9. IS 15301- Installation and Maintenance of Fire Fighting Pumps - Code of Practice
10. IS 5290- Landing valves

CHAPTER VII- APPOINTMENT OF FIRE SAFETY EXECUTIVE

27. Appointment of Fire Safety Executive

27.1 A qualified Fire Safety Executive with experience of not less than 3 years in providing and maintaining the fire prevention, life safety and fire protection measure shall be appointed by the owner / occupier / developer who will be available on the premises, for:

- a) educational buildings with height 15 m and above or having students enrolled more than 5000,
- b) business buildings with height 30 m and above,
- c) residential building with height 60 m and above,
- d) institutional buildings of 15 m and above,
- e) starred hotels (hotels duly approved by the concerned authorities as Five Star and above hotels),
- f) buildings of 15 m and above or having built-up area of more than 10,000sqmt for assembly of people provided with multiple services / facilities like shopping, cinema theatres, multiplexes, restaurants / food court,
- g) Hazardous and storage (below 15 mtrs, ground plus one or more floors), category buildings/premises (not covered under the factory act 1948) and Multi level car parking.
- h) open stadia with seating capacity more than 50,000 persons and indoor stadia with seating capacity more than 25,000 persons, and.
- i) public and semi-public buildings like large surface and sub-surface railway stations, interstate bus terminus, airports, amusements parks and other similar buildings

27.2 The Fire Safety Executive shall,

- a) maintain the firefighting equipment in good working condition at all times.
- b) prepare fire orders and fire operational plans and get them promulgated.
- c) impart regular training to the occupants of the buildings in the use of firefighting equipment provided on the premises and keep them informed about the fire emergency evacuation plan.
- d) keep proper liaison with the nearby fire station.
- e) ensure that all fire precautionary measures are observed at all the times.

27.3 On the advice of the Director, State Fire Prevention Services, the Competent Authority in their jurisdiction may direct appointment of Fire Safety Executive in case of buildings which do not fall under Regulation No. 27.

CHAPTER VIII- MISCELLANEOUS PROVISIONS

28 Safety and Maintenance of Buildings:

28.1 It shall be the duty of owner or the occupiers to maintain and keep in perfect working order, at all times, all the fire prevention, life safety and fire protection measures provided in the building and shall make arrangements to impart the operational knowledge to all the occupiers and the supportive staff at regular intervals and shall also conduct the fire drill at regular intervals. Owner or occupiers may take help of fire safety officer in this regard.

- 28.2** All staff members of all kind of occupancies which requires fire safety certificate, should be trained for firefighting and evacuations by the Fire Safety officers/Fire safety executive.
- 28.3** It shall be the responsibility of the owner / occupier/ builder/ developer to maintain and operate the electrical installations in a condition free from danger and as recommended by the manufacturer or by the relevant codes of practice of the Bureau of Indian Standards. The copy of self-certification with regard to same as contemplated in regulation No. 5A and 30 of the Central Electricity Authority (Measures relating to Safety and Electric Supply) Amendment Regulations, 2015 in the format at **ANNEXURE 15** shall be invariably submitted at the time of seeking fire safety certificate and at the time of its renewal.

29 Fire protection requirements during construction of buildings

During the construction of any building/s or for development on the site, minimum safety measures, as specified in National Building Code of India.

30 Use of web portal

All the application for fire safety plan approval (FSPA), fire safety certificate approval (FSCA), fire safety certificate renewal (FSCR/FSCRe) for new as well as existing buildings already having fire safety certificate (earlier known as fire NOC/opinion) shall necessarily be made on the web portal <https://gujfiresafetycop.in>. In case of difference in the format / content of annexure attached with these regulations and also various Forms of the Rules with the format / contents of said web portal, the format / contents mentioned in the web portal <https://gujfiresafetycop.in> shall prevail.

31 Effect of other laws

- 31.1** With regard to the manner of application, the documents to be submitted along with the applications, the protocols of drawings to be submitted, etc. unless otherwise prescribed, the provisions of CGDCR shall apply mutatis mutandis.
- 31.2** Notwithstanding anything contained in regulations of any relevant law, for the purpose of fire prevention, life safety and fire protection measures, these regulations shall be applicable.
- 31.3** Having obtained fire safety certificate or fire safety plan approval under these regulations, shall not be deemed to have obtained permissions under other relevant law.
- 31.4** Wherever reference of National Building Code is mentioned in the Gujarat Fire Prevention and Life Safety Measures Regulations, 2023 shall be read as National Building Code of India - latest edition. Similarly, in case of Indian Standard/ BIS code, the revised or latest Indian standard/ BIS code for the relevant subject matter shall be followed.

32 Overriding Effect

- 32.1** In case, where these regulations are not in sync with the regulations made under any other act then the regulations under Fire Act shall prevail.
- 32.2** In case, where these regulations pertaining to Fire prevention and life safety measures are not in sync with the GIFT area development control regulations, 2011 and subsequent amendments, the GIFT area development control regulations shall prevail.

By order and in the name of the Governor of Gujarat,

B. S. MISTRY,

Deputy Secretary to Government.

ANNEXURE 1**APPLICATION FOR FIRE SAFETY PLAN APPROVAL (FSPA)***(See Regulation 5.1)*

No.

To,**The Regional Fire Officer / Chief Fire Officer**

Subject: Application for Fire Safety Plan Approval (FSPA)**Sir/Madam,**

The applicant is the Owner/Developer/Builder of the building/ premise (name of the Building/Project) as per details below: -

Postal Address:

TP Number:

FP Number:

Survey Number and Village Name:

Part A

Height of Building (In Meter):

Site Area/Plot Area (In Sq.Meters):

Total Floor Area (In Sq.Meters):

Total Covered Area (In Sq.Meters):

Total Built-up area (In Sq.Meters):

No. of Floors (Including Basement Floors):

To undertake the construction of the aforesaid building/ premises, a Fire Safety Plan has been prepared, consisting of below mentioned drawings/ documents, which have been duly certified by Licensed Agency (LA) / Architect on Record (AoR) / Engineer on Record (EoR) / Structural Engineer on Record (SEoR) as prescribed in the GFP&LSM Act-2013, GFP&LSM Rules-2014, GFP&LSM Regulations-2023 and CGDCR, as amended from time to time, relevant for the purpose, and is submitted for your review:

- Layout plan (showing Fire Vehicle Access)
- Elevation
- AA section (indicating design, height of each floor, total height of building)
- Typical floor plans of each type of floor (with Occupant Load, Exit Capacity, Travel Distances, Compartmentation and line drawing of fire protection systems clearly marked)
- Checklist for Fire Protection Measures (Type ___)

You are requested to kindly examine the above and accord Fire Safety Plan Approval, for construction of the building/premises with the adequate measures.

Place :

Signature of Applicant

Date :

Name of the Owner / Developer / Builder:

.....

Address:

Tel: No.....

Mobile No.....

Email ID.....

Part B

I certify that information provided in Part A is correct to the best of my knowledge.

I also certify that the design of the above building project meets all relevant requirements of GFP&LSM Act-2013, GFP&LSM Rules-2014, GFP&LSM Regulations-2023 and CGDCR, as amended from time to time.

Place:

Place:

Date:

Date:

Licensed Agency (LA) Architect on Record (AoR)/ (Registration No. & Stamp)

Engineer on Record (EoR)/

Structural Engineer on Record (SEoR)

(Registration No. & Stamp)

ANNEXURE 2**FIRE SAFETY PLAN APPROVAL (FSPA)***(See Regulation 5.2)*

No.

To,

Name of the Applicant:

Address:

Tel: No..... Mobile No..... Email ID.....

This has reference to your Application No. dated, for Fire Safety Plan Approval (FSPA) for the building/ premise (name of the Building/ Project), as per details below:-

TP Number:

FP Number:

Survey Number:

Village Name:

Name of Block(s):

Your documents and information submitted on the www.gujfiresafetycop.in were reviewed, examined and were found in compliance with the requirements of GFP&LSM Act-2013, GFP&LSM Rules-2014, GFP&LSM Regulations-2023 and CGDCR as amended from time to time.

It shall be the responsibility of the applicant builder/ owner/ developer and the architect/engineer on record to comply with all relevant statutory requirements for fire protection as stated in the GFP&LSM Act-2013, GFP&LSM Rules-2014, GFP&LSM Regulations-2023 and CGDCR, as amended from time to time, and to also comply all such conditions as described in the Fire Safety Plan application itself. The applicant builder/ owner/ developer have to also comply with conditions which are annexed with this Fire Safety Plan Approval certificate.

Accordingly, **Fire Safety Plan is hereby approved.**

Place:

Date:

Signature

(Name, Designation & Stamp of the Authorized Signatory)

CC to – Town Planning Dept.**Office Copy**

ANNEXURE 3**FIRE SAFETY PLAN REJECTION***(See Regulation 5.2)*

No.

To,

Name of the Applicant:.....

Address:

Tel: No..... Mobile No..... Email ID.....

This has reference to your Application No. dated, for Fire Safety Plan Approval (FSPA) for the building/ premise (name of the Building/ Project), as per details below: –

TP Number:

FP Number:

Survey Number:

Village Name:

Name of Block(s):

The owner is required to address the following comments and re-apply for Fire Safety Plan Approval (FSPA).

Fire Department Comments:

a)

b)

Based on scrutiny of submitted documents, the applicant has not provided all the documents in accordance with the requirements stated, and/or Fire Safety Plan does not comply with GFP&LSM Act-2013, GFP&LSM Rules-2014, GFP&LSM Regulations-2023 and CGDCR, as amended from time to time.

Accordingly, the submitted **Fire Safety Plan is, therefore, rejected** and the applicant is instructed to resubmit the application for Fire Safety Plan Approval (FSPA).

Place:

Date:

Signature

(Name, Designation & Stamp of the Authorized Signatory)

CC to – Town Planning Dept.**- Office Copy**

ANNEXURE 4
REJECTION OF FIRE SAFETY CERTIFICATE

(See Regulation 5.5)

No.

To,

Name of the Applicant:.....

Address:

Tel: No.....

Mobile No.....

Email ID.....

This has reference to your Application No. dated, for Fire Safety Certificate for the building/ premise (name of the Building/ Project), as per details below mentioned details:-

TP Number:

FP Number:

Survey Number:

Village Name:

Name of Block(s):

Based on scrutiny of submitted documents, the applicant has not provided all the documents in accordance with the requirements stated, and/or Fire Safety Certificate application does not comply with GFP&LSM Act-2013, GFP&LSM Rules-2014, GFP&LSM Regulations-2023 and CGDCR, as amended from time to time. **The Fire Safety Certificate is, therefore, rejected.**

The Applicant is required to address the following comments and reapply for Fire Safety Certificate Approval, after re-payment of Fees.

Reason for Rejecting FSC Application -

a)

b)

Place:

Date:

Computer Id.:

Signature

(Name, Designation & Stamp of the Authorized Signatory)

CC to – Town Planning Dept.

- Office Copy

ANNEXURE 5

NOTICE FOR APPOINTMENT OF FIRE SAFETY OFFICER UNDER SECTION 12 OF THE ACT

(See Regulation 7.4)

WHEREAS the building or premises named as

.....

located at

.....

is comprised of

.....

and is covered under Third Schedule of the Rules.

AND WHEREAS the owner/occupier/an association of such owners and occupiers were required to appoint a Fire Safety Officer under section 12 of the Act.

NOW THEREFORE, Ion behalf of Director/Nominated Authority appointed under the Act, call upon you to appoint a Fire Safety Officer under sub-section (1) of section 12 of the Act within.....days failing which the owner or occupier or an association of such owners and occupiers shall be deemed to be in default jointly and severally and penal action shall be initiated without any further notice or opportunity.

Signature

(Name)

Regional Fire officer/

Chief Fire Officer

Place:

Date:

To

The owner/occupier/an association of such owners and occupiers

ANNEXURE 6**REJECTION OF FIRE SAFETY CERTIFICATE RENEWAL***(See Regulation 7.6)*

No.

To,

Name of the Applicant:.....

Address:

Tel: No..... Mobile No..... Email ID.....

This has reference to your Application No. dated, for Fire Safety Certificate Renewal – New Building (FSCR)/ Existing Building (FSCRe) for the building/ premise (name of the Building/ Project), as per details below mentioned details;

TP Number:

FP Number:

Survey Number:

Village Name:

Name of Block(s):

The building/premises was inspected by me on (Date of inspection) and it was observed that there are major non-compliances in the building/ premises as stated in comments below, which according to me, impact the fire and life safety hazards in the building/ premises.

Non-Compliances Observed:

- a. Non-compliance No. 1
- b. Non-compliance No. 2

The Fire Safety Certificate is therefore NOT RENEWED and you are requested to contact the Regional Fire Officer (Fire Service/ Region) to resolve the matter.

Place:

Date:

Signature of FSO

FSO Name & Registration No.

CC – Regional Fire Officer/ Chief Fire Officer
- **Town Planning Office**

ANNEXURE 7**CHECKLISTS TO BE ATTACHED WITH APPLICATION FORMS***(see regulation No. 9.2)*

	Checklists to be attached with application for -	ANNEXURE Nos.
A	Fire Safety Plan Approval (FSPA)	7.1 to 7.46
B	Fire Safety Certificate Approval (FSCA)	7.47 to 7.92
C	Fire Safety Certificate Renewal (FSCR)	7.93 to 7.138
D	Fire Safety Certificate Renewal (FSCRe) for existing buildings/premises having FSCA issued before this Regulation	7.139 to 7.183

NOTE

1. Total of 183 checklists each for different category of occupancies of the building / premises is uploaded on the web portal <https://gujfiresafetycop.in>.
2. Contents of checklist in the web portal <https://gujfiresafetycop.in> shall be treated as final.
3. Item No. A, B and C of each of the 183 checklists being same hence not repeated in all the checklists.
4. References related to National Building Code of India in the checklists for Fire Prevention and Life Safety for Item No. A, B and C are non-mandatory. However, it is recommended to adhere to them to the best extent possible as a good practice.

ANNEXURE 8

APPLICATION FEES FOR FSPA, FSCA AND FSCR

(See Regulation 5.3 & 10)

(Requisite fees shall be as may be prescribed by the Government from time to time.)

Occupancy / Main Category Type	Occupancy Sub-Type	Common Names/ Terms Used/Description	Sub-Category for which Fire Safety Certificate is mandatorily required	Application fee for			Checklist Form Code
				FSPA (in Rs)	FSCA (Rs/m ² of Built Up Area)	FSCR (in Rs)	
1	2	3	4	5	6	7	8
Residential & Lodging	Dormitories, Flats, Hostels & Apartment Houses etc.	Flats, Apartment Blocks, Residential Towers, Dormitories, Chawls, Military or Non-military Barracks, PG Accommodation, Hostels of School/University/Training Institutes and similar accommodations etc.	15 m and above but not exceeding 35 m in height	1000	10	1000	C1R1
			Above 35 m but not exceeding 45 m in height	2500	12	2500	C1R2
			Above 45 m but not exceeding 60 m in height	5000	15	5000	C1R3
			Above 60 m in height	7000	20	7000	C1R4
	Hotels & Guest Houses etc. (Below 5 star)	Hotels (Below 5 star), Motels, Guest Houses, Dharamshala, Resorts and similar lodging structures and buildings	Less than 15 m in height Floor area exceeding 500 m ² but not more than 1000 m ² on any of the floor	1500	15	1500	C1R5
			Less than 15 m in height Floor area exceeding 1000 m ² on any of the floor	2500	20	2500	C1R6
			15 m and above but not exceeding 30 m in height	1000	10	1000	C1R7
			Above 30 m in height	5000	30	5000	C1R8
	Hotels (5 star or above)	5 Star and above Hotels and Resorts	All 5 Star and above Hotels and Resorts	7000	50	7000	C1R9
	Educational Institute (Non-Residential part)	Schools (Non-Residential)	Primary/Secondary School (Non-Residential), Gurukul (Non-Residential) and similar buildings (residential blocks of such institutions shall be covered under separate appropriate category)	More than 9 m (but less than 15 m) in height irrespective of floor area or Floor area more than 500 m ² on any one or more floors	1000	7	1000

Occupancy / Main Category Type	Occupancy Sub-Type	Common Names/ Terms Used/Description	Sub-Category for which Fire Safety Certificate is mandatorily required	Application fee for			Checklist Form Code
				FSPA (in Rs)	FSCA (Rs/m ² of Built Up Area)	FSCR (in Rs)	
1	2	3	4	5	6	7	8
			15 m and above but not exceeding 24 m in height	2500	10	2500	C2ED2
			Above 24 m but not exceeding 30 m in height	5000	10	5000	C2ED3
	Other Educational and Training Institutions (Non-Residential)	College Building (Non-Residential), University Building Blocks (Non-Residential part) Technical Institutes (Non-Residential part), Polytechnic, ITI etc. (residential blocks of such institutions shall be covered under separate appropriate category)	More than 9 m (but less than 15 m) in height irrespective of floor area or Floor area more than 500 m ² on any one or more floors	1000	7	1000	C2ED1
			15 m and above but not exceeding 24 m in height	2500	10	2500	C2ED2
			Above 24 m but not exceeding 30 m in height	5000	10	5000	C2ED3
Institutional (Hospital, Correctional Facility, Care Centers etc.)	Hospitals, Sanatoria & Nursing Homes etc.	Hospital, Nursing Homes, Sanatoria, Wellness Centers, Trauma Centres, Children and Other Specialty Hospitals, ICU Centres etc. (except pure OPD clinics, psychiatric clinics and hospitals etc. which fall under separate categories)	Less than 15 m in height but with plot area upto 1000 m ² and having upto ground plus one storey with beds or Floor area more than 500 m ² on any one or more floors	1000	7	1000	C3I1
			Less than 15 m in height but with plot area upto 1000 m ² having Ground plus two or more storey with beds or Floor area more than 500 m ² on any one or more floors	1500	8	1500	C3I2

Occupancy / Main Category Type	Occupancy Sub-Type	Common Names/ Terms Used/Description	Sub-Category for which Fire Safety Certificate is mandatorily required	Application fee for			Checklist Form Code
				FSPA (in Rs)	FSCA (Rs/m ² of Built Up Area)	FSCR (in Rs)	
1	2	3	4	5	6	7	8
			Less than 15 m in height with plot area more than 1000 m ²	1000	9	1000	C3I3
			15 m and above but less than 24 m in height	2500	10	2500	C3I4
			Above 24 m and not exceeding 45 m in height	5000	15	5000	C3I5
	Custodial	Old-Age Homes, Senior Citizen Residences, Orphanages, Convalescent Homes, Correctional Homes etc.	Less than 10 m in height and having capacity upto 300 persons	1000	7	1000	C3I6
			Less than 10 m in height and having capacity more than 300 persons	1000	7	1000	C3I7
			10 m and above but not exceeding 15 m in height	2500	8	2500	C3I8
			15 m and above but not exceeding 24 m in height	3000	10	3000	C3I9
			24 m and above but not exceeding 30 m in height	5000	15	5000	C3I10
			Penal & Mental Facilities etc.	Prisons, Jails, Detention Homes, Juvenile Homes, Mental Hospital, Psychiatric Hospitals etc.	Less than 10 m in height and having capacity upto 300 persons	1000	7
	Less than 10 m in height and having capacity more than 300 persons	1000			7	1000	C3I7
	10 m and above but not exceeding 15 m in height	2500			8	2500	C3I8
	15 m and above but not exceeding 24 m in height	3000			10	3000	C3I9
	24 m and above but not exceeding 30 m in height	5000			15	5000	C3I10

Occupancy / Main Category Type	Occupancy Sub-Type	Common Names/ Terms Used/Description	Sub-Category for which Fire Safety Certificate is mandatorily required	Application fee for			Checklist Form Code
				FSPA (in Rs)	FSCA (Rs/m ² of Built Up Area)	FSCR (in Rs)	
1	2	3	4	5	6	7	8
Assembly (Permanent Structures like - Cinema Halls, Party Plot, Stadium, Shopping Malls, Stations etc.)	Cinema , Multiplexes, Concert Halls, Studios (with audience facility), Auditoriums, Theatres etc.	Cinema , Multiplexes, Concert Halls, Studios (with audience facility), Auditoriums, Theatres, Court Rooms, Lecture Halls, Town Halls etc.	Less than 10 m in height (from 50 upto 300 persons)	1000	8	1000	C4A1
			Less than 10 m in height (more than 300 persons)	1500	9	1500	C4A2
			Above 10 m but not exceeding 15 m in height, irrespective of capacity	2500	12	2500	C4A3
			Above 15 m but not exceeding 24 m in height, irrespective of capacity	3000	15	3000	C4A4
			Above 24 m but not exceeding 30 m in height, irrespective of capacity	5000	20	5000	C4A5
	Party Plots (indoor), Marriage Halls, Community Centre, Banquet Halls, Court Rooms, Lecture Halls, Town Halls etc.	Party Plots (indoor), Marriage Halls, Community Centre, Banquet Halls, Court Rooms, Lecture Halls, Town Halls etc.	Less than 10 m in height (from 50 upto 300 persons)	1000	8	1000	C4A1
			Less than 10 m in height (more than 300 persons)	1500	9	1500	C4A2
			Above 10 m but not exceeding 15 m in height, irrespective of capacity	2500	12	2500	C4A3
			Above 15 m but not exceeding 24 m in height, irrespective of capacity	3000	15	3000	C4A4
			Above 24 m but not exceeding 30 m in height, irrespective of capacity	5000	20	5000	C4A5

Occupancy / Main Category Type	Occupancy Sub-Type	Common Names/ Terms Used/Description	Sub-Category for which Fire Safety Certificate is mandatorily required	Application fee for			Checklist Form Code	
				FSPA (in Rs)	FSCA (Rs/m ² of Built Up Area)	FSCR (in Rs)		
1	2	3	4	5	6	7	8	
	Religious Structure, Museum, Heritage Monument	Religious Structure, Museum, Heritage Monument	Less than 10 m in height (from 50 upto 300 persons)	1000	8	1000	C4A1	
			Less than 10 m in height (more than 300 persons)	1500	9	1500	C4A2	
			Above 10 m but not exceeding 15 m in height, irrespective of capacity	2500	12	2500	C4A3	
			Above 15 m but not exceeding 24 m in height, irrespective of capacity	3000	15	3000	C4A4	
			Above 24 m but not exceeding 30 m in height, irrespective of capacity	5000	20	5000	C4A5	
	Airport Terminal Buildings, Enclosed Railway Stations, Enclosed Bus Depots, Rapid Mass Transit Terminus, Multi-modal Transport Hub, Maglev or High Speed Rail Stations, Inter-modal Hubs etc.	Airport Terminal Buildings, Enclosed Railway Stations, Enclosed Bus Depots, High Speed Rail Stations, Inter-modal Hubs etc.	Airport Terminal Buildings, Enclosed Railway Stations, Enclosed Bus Depots, Rapid Mass Transit Terminus, Multi-modal Transport Hub, Maglev or High Speed Rail Stations, Inter-modal Hubs etc.	Less than 10 m in height (from 50 upto 300 persons)	1000	8	1000	C4A1
				Less than 10 m in height (more than 300 persons)	1500	9	1500	C4A2
				Above 10 m but not exceeding 15 m in height, irrespective of capacity	2500	12	2500	C4A3
				Above 15 m but not exceeding 24 m in height, irrespective of capacity	3000	15	3000	C4A4
				Above 24 m but not exceeding 30 m in height, irrespective of capacity	5000	20	5000	C4A5

Occupancy / Main Category Type	Occupancy Sub-Type	Common Names/ Terms Used/Description	Sub-Category for which Fire Safety Certificate is mandatorily required	Application fee for			Checklist Form Code
				FSPA (in Rs)	FSCA (Rs/m ² of Built Up Area)	FSCR (in Rs)	
1	2	3	4	5	6	7	8
	Stadium, Sports Complex, Amusement Park, Recreational Center etc.	Stadium, Sports Complex, Amusement Park, Recreational Center etc.	Less than 10 m in height (from 50 upto 300 persons)	1000	8	1000	C4A1
			Less than 10 m in height (more than 300 persons)	1500	9	1500	C4A2
			Above 10 m but not exceeding 15 m in height, irrespective of capacity	2500	12	2500	C4A3
			Above 15 m but not exceeding 24 m in height, irrespective of capacity	3000	15	3000	C4A4
			Above 24 m but not exceeding 30 m in height, irrespective of capacity	5000	20	5000	C4A5
	Shopping Malls etc.	Shopping Malls, Shopping cum Entertainment Complex etc.	Irrespective of Area or Height	5000	25	5000	C4A6
	Metro & Mass Transport Systems	Train/ Metro / Hyperloop / Maglev Transport Systems (Underground & Elevated)	Irrespective of Area or Height	7000	25	7000	C4A7
Business & Offices	Offices including Banks, Professional Establishments, Public Offices, Police Stations etc.	Offices including Banks, Professional Establishments, Public Offices, Police Stations etc.	Above 15 m but not exceeding 24 m in height or Floor area more than 500 m ² on any one or more floors	1000	10	1000	C5B1
			Above 24 m but not exceeding 30 m in height	2500	15	2500	C5B2
			Above 30 m in height	5000	20	5000	C5B3
	Outpatient (OPD) Clinics, Research Establishments,	Outpatient (OPD) Clinics, Research Establishments, Libraries, Laboratories and	Above 15 m but not exceeding 24 m in height or Floor area more	1000	10	1000	C5B1

Occupancy / Main Category Type	Occupancy Sub-Type	Common Names/ Terms Used/Description	Sub-Category for which Fire Safety Certificate is mandatorily required	Application fee for			Checklist Form Code
				FSPA (in Rs)	FSCA (Rs/m ² of Built Up Area)	FSCR (in Rs)	
1	2	3	4	5	6	7	8
	Libraries, Laboratories and Test Houses	Test Houses	than 500 m ² on any one or more floors				
			Above 24 m but not exceeding 30 m in height	2500	15	2500	C5B2
			Above 30 m in height	5000	20	5000	C5B3
	Electronic Data Centres, Computer Installations, IT parks, Call Centers etc.	Electronic Data Processing Centres, Stock Exchanges, IT Parks, Call Centres, etc.	Above 15 m but not exceeding 24 m in height or Floor area more than 500 m ² on any one or more floors	1000	10	1000	C5B1
			Above 24 m but not exceeding 30 m in height	2500	15	2500	C5B2
			Above 30 m in height	5000	20	5000	C5B3
	Telephone Exchanges etc.	Telephone Exchanges & similar buildings etc.	Above 15 m but not exceeding 24 m in height or Floor area more than 500 m ² on any one or more floors	1000	10	1000	C5B1
			Above 24 m but not exceeding 30 m in height	2500	15	2500	C5B2
			Above 30 m in height	5000	20	5000	C5B3
	Broadcasting Stations, TV Stations, Air Traffic Control	Broadcasting Stations, TV Stations, Air Traffic Control etc. and similar buildings	Above 15 m but not exceeding 24 m in height or Floor area more than 500 m ² on any one or more floors	1000	10	1000	C5B1
			Above 24 m but not exceeding 30 m in height	2500	15	2500	C5B2
			Above 30 m in height	5000	20	5000	C5B3

Occupancy / Main Category Type	Occupancy Sub-Type	Common Names/ Terms Used/Description	Sub-Category for which Fire Safety Certificate is mandatorily required	Application fee for			Checklist Form Code
				FSPA (in Rs)	FSCA (Rs/m ² of Built Up Area)	FSCR (in Rs)	
1	2	3	4	5	6	7	8
Mercantile & Shops	Mercantile Buildings including Super Store, Super Market, Department Store, Wholesale Market buildings etc.	Super Store, Super Market, Department Store, Wholesale Market buildings, Large Shopping Complexes (other than shopping malls and large shopping cum entertainment cum eating complexes) etc.	Less than 15 m in height (but having either Ground storey + one, having total floor area > 500 m ²)	1000	10	1000	C6M1
			Above 15 m but not exceeding 24 m in height	2500	12	2500	C6M2
			Above 24 m but not exceeding 30 m in height	5000	15	5000	C6M3
	Underground Shopping Complex	Underground shopping centres & similar buildings, etc.	Irrespective of area and number of floors	5000	15	5000	C6M4
Storage, Warehouses, Transport Terminal & Parking	Storage, Transport terminal, Warehousing etc.	Godown, Warehouse, Storehouse, Depot, Cold Storage, Freight Depots, Transit Sheds, Truck Terminals, Marine Terminals, Barns, etc.	Covered area > 250 sqmtrs (for buildings less than 15 mtrs in height and having Ground floor only)	2500	10	2500	C8S1
			Covered area > 250 sqmtrs (for buildings less than 15 mtrs in height and having Ground + 1 floor only)	2500	15	2500	C8S2
			Covered area > 250 sqmtrs (for buildings less than 15 mtrs in height and having more than Ground + 1 floors)	5000	20	5000	C8S3
	Multi-level vehicle parking	Multi-level vehicle parking & similar buildings	All types of Multi-level Vehicle Parking	5000	20	5000	C8S4
Hazardous or Flammable Material Storage &	Hazardous or flammable material Storage and Handling	LPG Cylinder Storage, Hazardous Gas Storage, Flammable Liquid Store, Fireworks warehouse,	Single Storey building	5000	20	5000	C9H1
			More than one	7000	30	7000	C9H2

Occupancy / Main Category Type	Occupancy Sub-Type	Common Names/ Terms Used/Description	Sub-Category for which Fire Safety Certificate is mandatorily required	Application fee for			Checklist Form Code
				FSPA (in Rs)	FSCA (Rs/m ² of Built Up Area)	FSCR (in Rs)	
1	2	3	4	5	6	7	8
Handling		Explosive Store/Warehouse, Ammunition Depots, Petrol Pump, Gas Station, Storage & Handling of Materials such as Acetylene, Hydrogen, Chlorine, Phosgene, Methyl Oxide, Rocket propellants and similar materials	floor building (but should be less than 15 mtrs)				
Mixed Use Occupancies	Mixed Use (Buildings having more than one type of occupancy like - residential, commercial, business or mercantile)	Commercial Centres (Business cum Mercantile), Residential cum Commercial building, Residential cum Business buildings etc..	Buildings above 9 m in height (or above Ground plus two floors) or Floor area more than 500 m ² on any one or more floors	2500	10	2500	C10MX1
			Above 15 m but not exceeding 24 m in height	2500	10	2500	C10MX2
			Above 24 m but not exceeding 30 m in height	5000	20	5000	C10MX3
			Above 30 m in height	5000	20	5000	C10MX4
Temporary Structures	Tents, Circus, Events, Exhibitions, Religious Gatherings, Political and Social Gatherings, Trade Show, Camps, Shelters etc.	Tents, Circus, Events, Exhibitions, Religious Gatherings, Political and Social Gatherings, Trade Show, Camps, Shelters etc.		NA	2,000 (lump sum)	NA	Annex 10, GFP&LSM-2023

ANNEXURE 9

APPLICATION FEES FOR FSCRe

(See Regulation 10)

(Requisite fees shall be as may be prescribed by the Government from time to time.)

Occupancy/ Main Category Type	Occupancy Sub-Type	Sr. No.	Building Categories	Application Fee (in Rs) Lump sum	Checklist Form Code	
1	2	3	4	5	6	
Residential & Lodging	Apartments (Residential)	1	Building Height>15m but less than 25m	1000	C1R1-Re	
		2	Building Height>25m but less than 45m	2500	C1R2-Re	
		3	Building Height>45m	5000	C1R3-Re	
		Dharamshala	4	Building Height>15m	2500	C1R4-Re
		Hostel	5	Irrespective of area and height	2500	C1R5-Re
	Hotel, Motel	6	Building height<12m (upto total 30 rooms or not exceeding 300 m ² on each floor)	2500	C1R6-Re	
		7	Building height>12m (more than total 30 rooms or exceeding 300 m ² on any one floor).	5000	C1R7-Re	
	Starred Hotels	8	Upto4 Starred Hotels	2500	C1R8-Re	
		9	5 Starred and above Hotels	5000	C1R9-Re	
Educational Institute (Non-Residential part)	Educational (School/College)	10	Building Height >9m but upto 15m	1000	C2ED1-Re	
		11	Building Height >15m but less than 30m	2500	C2ED2-Re	
		Preschool	12	Building Height >9m	1000	C2ED3-Re
		Coaching Class	13	Building Height >9m	2500	C2ED4-Re
		Training centre	14	Building Height >9m	2500	C2ED5-Re
Institutional (Hospital, Correctional Facility, Care Centers etc.)	Institutional (Mental, Penal Institutions)	15	Building Height upto 15m	1000	C3I1-Re	
		16	Building Height>15m	2500	C3I2-Re	
	Health (Hospitals)	17	Building Height<15m (with plot area upto 1000 m ²)	1000	C3I3-Re	
		18	Building Height<15m (with plot area more than 1000 m ²)	2500	C3I4-Re	
		19	Building Height>15m (upto 24m)	5000	C3I5-Re	
		20	Building Height> 24m	5000	C3I6-Re	
Assembly (Permanent)	Restaurant	21	Irrespective of area and height	2500	C4A1-Re	
	Fitness centre	22	Irrespective of area and height	2500	C4A2-Re	

Occupancy/ Main Category Type	Occupancy Sub-Type	Sr. No.	Building Categories	Application Fee (in Rs) Lump sum	Checklist Form Code
1	2	3	4	5	6
Structures like - Cinema Halls, Banquet Halls, Stadium, etc.)	Community hall	23	Irrespective of area and height	2500	C4A3-Re
	Banquet hall	24	Irrespective of area and height	2500	C4A4-Re
	Town hall	25	Irrespective of area and height	5000	C4A5-Re
	Auditorium	26	Irrespective of area and height	5000	C4A6-Re
	Convention centre	27	Irrespective of area and height	5000	C4A7-Re
	Planetarium	28	Irrespective of area and height	5000	C4A8-Re
	Stadium	29	Irrespective of area and height	5000	C4A9-Re
	Museum	30	Irrespective of area and height	2500	C4A10-Re
	Exhibition hall	31	Irrespective of area and height	5000	C4A11-Re
	Theatre	32	Irrespective of area and height	5000	C4A12-Re
	Cinema	33	Irrespective of area and height	5000	C4A13-Re
	Multiplex	34	Irrespective of area and height	5000	C4A14-Re
	Drive in Cinema	35	Irrespective of area and height	5000	C4A15-Re
Business & Offices	Mixed use or Business	36	Building Height>15m or G+4	2500	C5B1-Re
	Corporate offices	37	Building height>9m or G+2	2500	C5B2-Re
	Call centre	38	Irrespective of area and height	2500	C5B3-Re
Mercantile & Shops	Mercantile	39	Building height>9m or G+2	2500	C6M1-Re
	Shopping centre	40	Building height>9m or G+2	5000	C6M2-Re
	Wholesale market	41	Built up area>250 sqm	2500	C6M3-Re
Storage, Warehouses & parking	Storage Building	42	Built up area>250 sqm	5000	C8S1-Re
Hazardous or Flammable Material Storage & handling	Hazardous or Flammable Material Storage & handling	43	Built up area>100 sqm	5000	C9H1-Re
Religious Buildings	Religious building (Temple, Mosque, gurudwara, Church, etc.)	44	Built up area>250sqm	1000	C10RG1-Re
Fuel Dispensing Facilities	Petrol/Diesel/CNG dispensing pump	45	Irrespective of area and height	5000	C11FD1-Re

ANNEXURE 10
DECLARATION CUM CHECKLIST - FIRE SAFETY PERMISSION FOR
TEMPORARY STRUCTURE (PANDAL)

(See Regulation 13.2)

	Fire Safety Declaration No		
	Fire Region		
		Input by Applicant	Instructions / Explanation for Applicant
A. Applicant Details			
A1	Name of Pandal Owner/ Erector	Free Text	Provide Required Information
A2	Mobile Number of Pandal Owner/ Erector	Free Text	
A2.1	Alternative Mobile Number of Pandal Owner/ Erector	Free Text	
A3	Email ID	Free Text	
A3.1	Alternative Email ID	Free Text	
A4	Registered Office Address	Free Text	
B. Site/Location Details			
B1	City / Town / Village	Free Text	Provide Required Information
B2	Zone	Free Text	
B3	Ward	Free Text	
B4	Postal Address	Free Text	
B5	Pincode	Free Text	
B6	Lat / Long	Free Text	
B7	Taluka	Free Text	
B8	Dist Name	Free Text	
B9	Nearby Permanent Landmark	Free Text	
C. Temporary Structure (Pandal) Details			
C1	Use of Pandal	Free Text	Entertainment/ Religious/ Social Gathering
C2	Size of Pandal	____ Mtr x ____ Mtr	Provide dimensions
C3	Approach to proposed structure - width of the main road and - width of connecting roads (if any)	____ Meters ____ Meters	Provide dimensions
C4	Start Date (for use of Pandal)	DD/MM/YYYY	State Date from when use will start
C5	End Date (for use of Pandal)	DD/MM/YYYY	State Date when use will end
Fire Prevention, Life Safety & Fire Protection Measures			
D1	Height & Location		
D1.1	Minimum height of the ceiling of the temporary structure and pandal is not less than 3.00 meters.	Yes/ No	Ensure requirements are met and provide confirmation

D1.2	Structure is not erected under any live electrical line. It is minimum 15 meters away from the railway lines, electrical sub stations, furnaces and other hazardous places. If required, the minimum distance may be increased as directed by the Regional Fire Officer or the Chief Fire Officer.	Yes/ No	
D2	Means of Access		
D2.1	Pandal is approachable and the gate provided has a clear opening of 5 m. Height of archway is not less than 5 m from the ground level.	Yes/ No	Ensure requirements are met and provide confirmation
D2.2	No part of temporary structures is more than 45 m away from the motorable road	Yes/ No	
D3	Exits		
D3.1	Adequate number of exits have been provided for the calculated capacity of the pandal. Minimum two exits to be provided	Yes/ No	Ensure requirements are met and provide confirmation
D3.2	4.5mts margins is kept on all sides. Minimum width of the exits of the temporary structure and pandal is 2.5 mts, and located at extremities from each other.	Yes/ No	
D3.3	Line of travel from any seat to exit is not greater than 15 mt.	Yes/ No	
D3.4	All the space used in and outside the public gathering place is flat surface and entry/exit have a leveled surface without obstruction.	Yes/ No	
D3.5	All Exit signs are clearly indicated with Emergency Exit Signs (in local language)	Yes/ No	
D4	Electrical Arrangements		
D4.1	Temporary lighting has been installed by a Licensed Contractor.	Yes/ No	Ensure requirements are met and provide confirmation
D4.2	Electrical wires pass through PVC conduits and are not in contact with any flammable material. No loose wiring is used and all ends are properly taped and insulated.	Yes/ No	
D4.3	Big lights (halogen/halides) are at least 60 cms away from the rides or any metal structure temporarily constructed.	Yes/ No	
D4.4	Heavy cable connections are connected by ceramic connectors and then insulated along with the fuses. Power control switches, MCB or ELCB are installed for each circuit.	Yes/ No	
D4.5	Light fittings and lamps installed are not in contact with cloth or any other flammable material.	Yes/ No	
D4.6	Standby generators of appropriate capacities have been kept ready at the site in case of pandal having size more than 500 sq.mt	Yes/ No	

D5	Fire Prevention		
D5.1	Temporary structure (pandal) is made from fire resistant material	Yes/ No	Ensure requirements are met and provide confirmation
D5.2	No combustible material like wood shavings, straw, highly inflammable and explosive chemicals and similar materials are stored in the vicinity or inside the temporary structure and pandal.	Yes/ No	
D5.3	No fireworks display with open flames of any kind is being used in temporary structure and pandal.	Yes/ No	
D5.4	Kitchens are constructed 15 meters away from the temporary structure or pandal and are built using tin sheets.	Yes/ No	
D6	Fire Fighting		
D6.1	A 200 liter water barrel along with water buckets/sand buckets is placed not more than 50 mts distance.	Yes/ No	Ensure requirements are met and provide confirmation
D6.2	Water type, Dry chemical powder and CO2 type fire extinguishers are placed in required numbers at strategic locations. Quantity and location shall be fixed as given in IS:8758 & IS:2190, as applicable	Yes/ No	
D6.3	Name of the Person and his mobile number who is responsible for organizing evacuation and carry out firefighting during emergencies and informing the Fire Service	Free Text Name: Mobile :	
D6.4	Names of other Trained Fire Fighting Staff	1. 2. 3.	
D6.5	Every security guard and other supporting staff provided with a suitable torch for use during dark hours of operation.	Yes/ No	
D7	Other/ Attachments		
D7.1	All requirements related to fire prevention, life safety and fire protection as stated in GFP&LSM Regulations, 2023 and IS:8758 including Central Electricity Authority (measures relating to safety and electric supply) Regulations, 2010 have been complied with.	Yes/ No	Please read the requirements stated in referenced regulations and IS code of practice and provide confirmation.
D7.2	If purpose of temporary structure is to attract public gathering such as Circus, etc., have attachments as stated in E section been uploaded?	Yes/ No	Provide attachments stated in Section E and confirm.

E. Attachments (See D7.2)			
E1	Layout plan indicating access to the temporary structure or pandal.		Attach file (pdf)
E2	Plan showing location, dimensions and area of stalls, sanitary facilities and other uses,		Attach file (pdf)
E3	The plans showing the construction at the sites, if any		Attach file (pdf)
E4	Certificate with photograph from a registered electrical engineer to ensure proper load distribution and wiring in case of the temporary structure or pandal having size more than 500 sq.meters		Attach file (pdf)
E5	Any other plans or documents required the Regional fire Officer or the Chief Fire Officer.		Attach file (pdf)
		Submit Declaration	Will generate view of Application form, and on confirmation will upload the Application on Portal and generate Form C1

Form C1 (See Rule 28)		
DECLARATION BY ERECTOR OF PANDAL UNDER SECTION 27 OF THE ACT		
<p>I(name of the erector of pandal), having registered office at do hereby declare that the pandal erected at measuring..... meters by meters shall remain in place with effect from to and that fire prevention, fire safety fire protection measures as required under Regulation no. 10 of the Gujarat Fire Prevention and Life Safety Measures Regulations have been provided therein and further that the complete erection of pandal and electrical services are in conformity with the standards.</p> <p>Also, it is declared that no storage/use of the flammable liquid or gases is done in the pandal and that electrical wiring has been done in conformity with Indian Electricity Rules by authorized persons.</p>		
<p>I, also, declare that following trained firefighting staff shall remain on duty during the occupancy of the pandal:-</p> <p>1.</p> <p>2.</p> <p>3.</p>		
Date:		
Signature of Owner/ Erector of Pandal		
Photograph of Owner/ Erector of Pandal		

ANNEXURE 11*(See Regulation 8.5)***CHECKLIST FOR MOCK FIRE AND EMERGENCY DRILL**

Mock Fire and Emergency Drill Activities					Timeline
Sr. No.	Description	Details cum Compliance	FSO Remarks (if any)	Instructions for FSO	
A. Mock Fire and Emergency Drill Preparation					T1 (At least 5 minutes)
A1	Building details				To be taken from FSCoP system
A1.1	Name of the premise/ building				
A1.2	Address of the premise/building				
A1.3	Building Category				
A1.4	Name of Owner/Occupier				
A2	Name of FSO designated for the premises/ building	Mr./ Ms. / Mrs.			
A3	Drill Date		DD.MM.YYYY		To be taken from clock of mobile network or system time and date
A4	Drill/Building Location				Should be Geo tagged also by system
A5	Drill Scenario (brief description)	at least 200 words		Describe the scenario of fire accident. For example, a situation of electrical short circuit and subsequent fire or accidental fire due to oil spill and so on - including type of fire and its potential spread and so on.	
A6	Name of Drill Initiator	Mr./ Ms. / Mrs.		Drill initiator is a person who will see the fire accident and call to the concerns for further actions and initiate the drill (Refer Clause D-2 of Annex D of Part 4 of the NBC, code)	
A7	Names of Drill Observers			Drill observers will observe the various activities of drill and drill observer can be FSO, Fire officer from local/ private fire brigade, fire officer of same premises, member of premises/ area, fire professional, etc..)	

Mock Fire and Emergency Drill Activities					Timeline
Sr. No.	Description	Details cum Compliance	FSO Remarks (if any)	Instructions for FSO	
A7.1	Name of observer for drill - 1	Mr./ Ms. / Mrs.		To observe activities for Firefighting / rescue / casualty shifting / head count / fire staff activities / ambulance activity / action by security & safety dept. etc..	
A7.1.1	Contact Details	mobile number			
A7.2	Name of observer for drill - 2	Mr./ Ms. / Mrs.		To observe activities for public movement and evacuation activities	
A7.2.1	Contact Details	mobile number			
A7.3	Name of observer for drill - 3	Mr./ Ms. / Mrs.		To observe activities for public movement and evacuation activities	
A7.3.1	Contact Details	mobile number			
A8	Is opening meeting organized to discuss on basic planning about fire drill with key persons of premises/ building?	Yes/No		Opening meeting shall be organized by FSO to communicate effectively about fire drill and evacuation procedure to key members of premises/ building so, proper planning can be done for safe and effective drill.	Upload the meeting photograph from phone camera only with geo location and date-time stamping
A9	Is there a proper signage for identification of exits, stairs, floor number and lifts apart from emergency lights, floor plan placed at relevant locations?	Yes/No		Refer Clause D-9.9 of Annex D of Part 4 of the NBC, code	
A10	Is organization chart for fire drill and evacuation assignment designating employees and their assignments prepared and posted in a conspicuous places at each floor in premise/ building?	Yes/No		Refer Clause D-9.3.4 of Annex D of Part 4 of the NBC, code	Upload the photo of organization chart from phone camera only with geo location and date-time stamping
A11	Is latest approved Fire Safety Plan available with premise/ building and distributed to all tenants/employees/owners of premises?	Yes/No		Refer Clause D-9.10 of Annex D of Part 4 of the NBC, code	Upload the photo of cover page with date of latest Fire safety plan from phone camera only with geo location and date-time stamping
A12	Are personal fire instruction cards provided to occupants of	Yes/No		Refer Clause D-9.11 of Annex D of Part 4 of the	Upload the photo of Fire instruction

Mock Fire and Emergency Drill Activities					Timeline
Sr. No.	Description	Details cum Compliance	FSO Remarks (if any)	Instructions for FSO	
	the premises/ building and were they found with persons who participated in drill?			NBC, code	card to be taken from phone camera only with geo location and date-time stamping
A13	Is there any special arrangement done for persons with physical disabilities at premise/ building? Also, updated list of such persons available with command centre?	Yes/No		Refer Clause D-9.3.5 of Annex D of Part 4 of the NBC, code	
A14	Is fire warden identification provided with armband, etc.?	Yes/No		Refer Clause D-9.3.6 of Annex D of Part 4 of the NBC, code	Upload the photo of Fire warden with identification to be taken from phone camera only with geo location and date-time stamping
A15	Is Assembly point available at premise/ building?	Yes/No		Refer Fire Warden Instructions below Clause D-9.11 of Annex D of Part 4 of the NBC, code	Upload the photo of public gathering at assembly point to be taken from phone camera only with geo location and date-time stamping
	If yes, location of assembly point and name				
A16	Mock call to be made by the Drill initiator	Yes/No		Actual drill to start now.	
B. Drill Activation and Participant Mobilization					T2 (atleast 45 minutes)
Sr.No.	Description	Details cum Compliance	FSO Remarks (if any)	Instructions for FSO	
B1	Are fire extinguishers used in drill and observed effective working?	Yes/No		Refer Clause D-9.3.9 of Annex D of Part 4 of the NBC, code	Upload the photo of fire extinguisher operated by drill participants to be taken from phone camera only with geo location and date-time stamping

Mock Fire and Emergency Drill Activities					Timeline
Sr. No.	Description	Details cum Compliance	FSO Remarks (if any)	Instructions for FSO	
B1.1	Tag number of fire extinguishers which were operated in drill	Text box	Text box		
B2	Are fire hydrant points used in drill and observed effective working?	Yes/No/Not Applicable	Text box		Upload the photo of fire hydrant point operated to be taken from phone camera only with geo location and date-time stamping
B2.1	Tag number of fire hydrant(s) which were used in drill	Text box	Text box		
B3	Are fire pumps operated and found working effectively?	Yes/No/Not Applicable	Text box		Upload the photo of fire main header pressure gauge with pressure to be taken from phone camera only with geo location and date-time stamping
B3.1	Observed main header pressure of pumps	___ number ___ ___ kg/cm ²	Text box		
B4	Is fire water tank/ sump/ reservoir fully filled with water?	Yes/No			
B4.1	Availability (in ltrs) of fire water tank/sump / reservoir	___ ltrs		Mention available level of water in different types of tanks/sumps/reservoir (underground, overground or terrace) separately in "remarks" if more than one type of tank/sump is there	
B5	Is basic firefighting, rescue and evacuation training imparted to occupants before starting of drill?	Yes/No			Upload the photo of training attendance sheet with sign of participants to be taken from phone camera only with geo location and date-time stamping
B6	Are surrounding roads to the buildings or premises observed free from obstruction during drill and participants made aware about such surrounding details?	Yes/No			
B7	Is sprinkler system operated	Yes/No/Not			

Mock Fire and Emergency Drill Activities					Timeline
Sr. No.	Description	Details cum Compliance	FSO Remarks (if any)	Instructions for FSO	
	and observed working effectively? (if applicable)	Applicable			
B7.1	Is sprinkler head practically operated by fire torch?	Yes/No			
B7.2	Location of sprinkler head(s)operated				
B7.3	Was sprinkler head replaced after its operation?	Yes/No		Same technical specification sprinkler head shall be used for replacement immediately.	
B7.4	Is sprinkler head's performance/ pressure observed in effective condition?	Yes/No			Upload the photo of sprinkler operation to be taken from phone camera only with geo location and date-time stamping
B7.5	Is sprinkler pump operated and found effective working?	Yes/No/Not Applicable			
B8	Is fire alarm and detection system operated and observed working? (if applicable)	Yes/No/Not Applicable			
B8.1	Is fire detector automatically operated by fire torch or manual call point operated?	Yes/No			
B8.2	Is fire detector or manual call point re-set done after its operation?	Yes/No			
B9	Is there any error observed in panel of fire alarm and detection system?	Yes/No			
B10	Is mock evacuation done in effective and safe manner during drill?	Yes/No			
B11	Have all respective emergency response members (as per latest approved Fire Safety Plan) responded/ participated in the drill?	Yes/No		Emergency Response members include: Fire Safety Director, Deputy Fire Safety Director, Fire Warden, Deputy Fire Warden, Building Evacuation Supervisor, Fire Party etc.. Refer Clause D-8 and D-9 of Annex D of Part 4 of the NBC, code	

Mock Fire and Emergency Drill Activities					Timeline
Sr. No.	Description	Details cum Compliance	FSO Remarks (if any)	Instructions for FSO	
C. Head Count and Debriefing					T3 (Atleast 10 Minutes)
C1	Assemble participants at the assembly point and do head count of the drill participants	number			
C2	Is closing meeting organized to discuss on fire drill overall performance and observation/ finding with key persons of premise/ area?	Yes/No		Closing meeting shall be organized by FSO to conclude the drill exercise and communicate the observation/ findings to key persons of premises/ building. Participants to be also be informed regarding other emergency situations (like earthquake, electrocution and preventive and protective and post-event measures)	Upload the meeting photograph to be taken from phone camera only with geo location and date-time stamping
D. Concluding Remarks					T4 (Atleast 5 Minutes)
Observations and Recommendations					
D1	Observations (if any)				
D2	Recommendations (if any)				
D3 Attachments					Copy to be sent to concerned CFO / RFO and applicant / occupier / owner
D3.1	Video of fire drill training (4-5 minutes video clip, shot by)				

Mock Fire and Emergency Drill Activities					Timeline
Sr. No.	Description	Details cum Compliance	FSO Remarks (if any)	Instructions for FSO	
E. Mock Fire and Emergency Drill Completion (Timer ends and total mock drill time to be captured in report)					T5 (End)
E1	According to you, was the drill successfully completed?	Yes/ No		(In case of "No") Please enter details of non-successful completion of drill.	
Complete the Drill					
Next Fire Drill due Date					
	DD.MM.YYYY (To be displayed as the FSO Clicks submits and to be also notified and reflected to owner/occupier through SMS also, apart from being reflected in their account)				Should be system determined. Every six months - with a window of 30 days - 15 days prior and 15 days after due date. Both Building owner/occupier and FSOs should get advance notifications via SMS as well as mail and through app etc..
End and Report Generation					

ANNEXRE 12

(See Regulation 8.5)

INSPECTION CHECKLIST FOR FSO

Sr. No.	Description	Details cum Compliance	FSO Inspection Remarks (if any)	Instructions for FSO
IN1. Fire Inspection Preparation				
IN1.1	Name of FSO designated for the premises/ building	Mr./ Ms. / Mrs.		
IN1.2	Fire Inspection Date	DD.MM.YYYY		
IN1.3	Names of Persons who joined with FSO for inspection			Persons can be - fire officer of same premises, habitants of building/ premises etc., but should not be outsiders
IN1.4	Name of person - 1	Mr./ Ms. / Mrs.		
	Contact Details	mobile number		
IN1.5	Name of person - 2	Mr./ Ms. / Mrs.		
	Contact Details	mobile number		
IN2. Fire Prevention				
IN2.1	Are surrounding roads of the buildings or premise observed free from obstruction during inspection and occupier made aware about such surrounding details and their significance for fire and emergency operation?	Yes/No		If "no" then, write in remarks about basic details about such obstruction with exact location and nature of obstruction and the owner/occupier should be instructed to remove the obstruction
IN2.2	Is there any noticeable new construction or expansion of existing construction at building/ premises?	Yes/No		If "Yes" then, write in remarks about the basic details of new construction, like - location/ dimensions/type of use etc.
IN2.3	Are HVWS / N2 system/ other system(s) for transformers, heating and cooling units etc. working effectively in auto operation condition?	Yes/No / Not Applicable		Write observation in remarks if any deficiency is found in the systems. Observations like - For HVWS: Water leak in pipelines, deluge valve in manual mode, valves in close conditions, any part found damaged or missing from the system etc.. For N2 system: Hydro test due date over for N2 cylinders, any valve in closed condition, N2 cylinder having low weight, any part found damaged or missing from the system, system in manual mode etc..
IN2.4	Are Electrical MV main distribution panel (s) and lift panel(s) provided with CO2/inert gas flooding or equivalent fire protection system and working in auto operation condition?	Yes/No/ Not applicable		Enter details in case non-compliance is there

Sr. No.	Description	Details cum Compliance	FSO Inspection Remarks (if any)	Instructions for FSO
IN2.5	If a generator is there in the premise, is the generator in good operational health?	Yes/No / Not Applicable		Please check other parameters like - Is fuel level in the generator close to 100 % and is cooling water level in radiator filled with 100 % or healthy levels, engine oil in the engine filled till appropriate level? And is battery is good health and if wet type, filled with full water? Are emergency inter-connection operations functioning properly? If they are not in proper functional condition, write in remarks about non-compliance of particular point. It is not allowed and filled immediately if level low
IN2.6	Are the ventilation systems, including mechanical ventilation system, AHUs etc. working effectively?	Yes/No/ Not applicable		If "no", then write in remarks about non-compliance of particular point and ensure that necessary repairs/corrections are carried out
IN2.7	Whether a connecting cable from lightning arrestor to ground level earth pit is found healthy (check physical condition layout of cable) or not? Also, Is Lightning arrestor earth pit's periodic inspection did or not (check record)?	Yes/No/ Not applicable		If "no", then write in remarks about non-compliance and ensure that necessary repairs/corrections are carried out
IN3. Life Safety				
IN3.1	Are proper signage there for identification of exits, stairs, floor number and lifts apart from emergency lights, floor plan placed at relevant locations and adequate illumination with alternate power supply provided for safe movement of persons towards and through the exits (as applicable as per Fire Safety Certificate)?	Yes/No		See emergency evacuation floor plan and drawing for actual declared signages in approval copy of fire safety certificate issued by CFO/RFO. If compliance not there, then, write in remarks about location details with missing of signages and immediate compliance should be ensured
IN3.2	Is any exit or staircase or passage (lobby) location observed different at location as mentioned in original drawings at building/ premise?	Yes/No		See building GA/ floor plan drawing for actual declared EXIT/staircase/passage (lobby) in approval copy of fire safety certificate issued by CFO/RFO. If "yes" than, write in remarks about location details which has changes. Instruct for immediate compliance if non-compliance is there

Sr. No.	Description	Details cum Compliance	FSO Inspection Remarks (if any)	Instructions for FSO
IN3.3	Is any exit, exit door, egress path or staircase or passage (lobby) location found temporarily or permanently closed or obstructed at building/ premises?	Yes/No		If "yes" than, write in remarks about location details which has changes and details of temporarily or permanently closed or obstructed stairs, doors, egress paths etc.. Instruct for immediate compliance to be passed if non-compliance is there
IN3.4	Are basement(s), if any as per the FSCA, provided with obstruction free approach, has adequate ventilations, sprinklers etc. and no changes have been made in overall fire-safety requirements since the issue of Fire Safety Certificate or last renewal?	Yes/No/ Not applicable		Enter details in case non-compliance is there
IN4. Fire Protection				
IN4.1	Are the fire extinguishers, fire alarms and other fire equipment, as applicable, in place in building/premise as declared (quantity and technical specifications, capacity) in the Fire Safety Certificate Approval and they are all in good working condition?	Yes/No		Check for hydro testing of fire protection equipment wherever applicable, take note of condition of hydrant points, valves, hose reels, pipes, nozzles, fire pumps, voice evacuation system, intercom, fire detectors, MCP system, visual warning systems, auto operation wherever required. Note pressure gauge of fire hydrant system and see if it is appropriate. Hydro test has to be done once in 5 years for Co ₂ type and once in 3 years for DCP/Foam/ Water type extinguishers. Any issues related to main fire line valve closing, electrical motor problem, diesel engine problem, jockey pump issues, pipeline leakage or choking, water sump empty, pump house suction or delivery valve failure in closed condition etc. should be mentioned in remarks if "no" option is selected
IN4.2	Test sample fire equipment and write their tag numbers or serial numbers with other details			Write the tag number of fire pump, fire hydrant / hose reel / monitor, extinguishers, etc. in remarks

Sr. No.	Description	Details cum Compliance	FSO Inspection Remarks (if any)	Instructions for FSO
IN4.3	Are all delivery lines, suction line and main header valve of hydrant and sprinkler system in open and working condition? (if applicable) (Except valves of sprinkler testing line and bypass line/circular line at fire pump house)	Yes/No		If appropriate lines are found closed, they should be opened and the owner/occupier be instructed to keep them open. Write the tag number of valve with reason of closing, if found closed, in remarks
IN4.4	Is sprinkler system, if any as per Fire Safety Certificate, in the building/ premise in healthy condition and pressure gauge showing proper readings?	Yes/No /Not Applicable		Immediate attention needs to be paid if sprinkler systems have faults. Also check alarm valve/ deluge valve installed in sprinkler system and whether it is kept in auto mode. Check missing sprinkler heads if any and inspect sprinkler pump condition also. Details to be noted in remarks column
IN5. Other Inspection Points				
IN5.1	Are all electrical points, equipment in good condition, regularly serviced and does the building complies with various requirements of electrical safety as mentioned in GFP&LSM, regulations 2023 and as required by the Central Electricity Authority regulations and their amendments?	Yes/No/Not Applicable		If "no" then, write in remarks about non-compliance of particular points and direct the owner/occupiers for immediate action. Inspection and service record of the electrical equipment to be checked along the self-certification as required by the Central Electricity Authority regulations. Electrical panels to be checked and should not be found exposed and in hazardous condition
IN5.2	Is organization chart for emergency response and evacuation assignment designating employees and their assignments prepared and posted in a conspicuous place at each floor in premise/ building?			If it is not there, FSO to help the owner occupier to get it prepared and keep a sample handy with him or her and provide it to owner occupier in editable soft copy
IN5.3	Is latest approved Fire Safety Plan available with premise/ building and distributed to all tenants/employees/owners of premises?			If it is not there, FSO to help the owner occupier to get it prepared and keep a sample handy with him or her and provide it to owner occupier in editable soft copy

Sr. No.	Description	Details cum Compliance	FSO Inspection Remarks (if any)	Instructions for FSO
IN5.4	Are building staff / residents, selected as sample, found to be given firefighting training, as per conditions of the Fire Safety Certificate? Were they found conversant in the basic fire safety drills including operation of fire safety instruments like fire extinguishers?	Yes/No		Basic fire safety training record to be checked and owner/occupier should be guided how to maintain it. If no such training given till date, one to be organized and details to be entered in remarks
IN5.5	Was a closing meeting organized to discuss on fire inspection's overall compliance status details, observations and recommendations with key persons of building/ premise?	Yes/No		Participants to be also be informed regarding other emergency situations (like earthquake, electrocution and preventive and protective and post-event measures) and be given basic demonstration of equipment like fire extinguishers, operation of alarms, valves and so on
IN5.6	Concluding remarks and recommendations			
IN6. Attachment (if any)				
IN7. Inspection Completion				
Next Inspection due Date:				

ANNEXURE 13**SELF-CERTIFICATION FOR MAINTAINING FIRE SAFETY MEASURES***(See Regulation 2.3)*

Self-certification by the Owner/ Occupier/ Builder/ Developer for maintaining fire prevention, life safety and fire protection measures as per approved fire safety certificate and doing no alteration of any part of the building without approval of the competent authority

CERTIFICATE

Certified that I/We(Name of the owner/ occupier/ builder/ developer) have provided the necessary measures related to fire prevention, life safety and fire protection in the following building/ premise, as required under the provisions of the GFP&LSM Act-2013, GFP&LSM Rules-2014, GFP&LSM Regulations-2023 and CGDCR, as amended from time to time.

I/We(Name of the owner/ occupier/ builder/ developer) confirm that no alteration has been done on any part of the building without approval of the competent authority for the building as mentioned below: -

Postal Address:

TP Number:

FP Number:

Survey Number:

Village Name:

Name of Block(s):

Place. :

Date. :

(Signature)

Name and address of the

Owner/ occupier/ builder/ developer

[Note: For each building a separate certificate is necessary]

ANNEXURE 14**SELF-CERTIFICATION FOR ANNUAL MAINTENANCE CONTRACT***(See Regulation 2.3)*

Self-certification by the Owner/ Occupier/ Builder/ Developer having done Annual Maintenance Contract (AMC) for fire protection equipment and system installed in the building/ premise

CERTIFICATE

I/We(Name of Owner/ Occupier/ Builder/ Developer) hereby certify that an Annual Maintenance Contract has been done for Fire Protection Equipment and Systems installed in the building/ premise under the provisions of the GFP&LSM Act-2013, GFP&LSM Rules-2014, GFP&LSM Regulations-2023 and CGDCR, as amended from time to time.

I/We certify that _____(Name of the Agency) is providing Annual Maintenance Contract for Fire protection equipment and systems installed in the building or premise for a period of one year with effective from _____(start date of agreement) till _____(end date of agreement).

I/We(Name of the owner/ occupier/ builder/ developer) confirm that all the Fire Protection Equipment & Systems installed are well maintained and in operational condition in the building/ premise as mentioned below: -

Postal Address:

TP Number:

FP Number:

Survey Number:

Village Name:

Name of Block(s):

Place. :

Date. :

(Signature)

Name and address of the

Owner/ occupier/ builder/ developer

[Note: For each building a separate certificate is necessary]

ANNEXURE 15
SELF-CERTIFICATION FOR ELECTRICAL INSTALLATIONS
(See Regulation 2.3)

Self-certification by owner / occupier / builder / developer regarding
safe electrical installations inside building or premise

CERTIFICATE

I / We hereby certify that all the electrical installation inside the building or premise is conforming to the Central Electricity Authority (Measures relating to Safety & Electricity Supply) Regulation, 2010 and subsequent amendments for the below mentioned building or premises: -

Place:

Date:

(Signature)

Name of owner / occupier /
builder / developer
Mobile No.

(Signature)

Name of Chartered Electrical
Safety Engineer* / Electrical Inspector
Mobile No.

* Chartered Electrical Safety Engineer related provisions to come into force as and when notified by the Gujarat Government. Till then, this may be left blank and the certificate should be self-certified by the owner occupier.

[Note: For each building a separate certificate is necessary]

